

NPE Series

Tankless Water Heaters

Quick Facts Sheet



Navien Certification Summary

Model	Product Approvals						Efficiency Ratings			Annual Energy Consumption (Residential)		
	CSA	NSF (Standard 5)	Low Lead (<0.25%)	SCAQMD 1146.2 (NOx, <20ppm)	AHRI Number	Energy Star	Energy Factor (EF)	Uniform Energy Factor (UEF)	Max GPM (77°F Rise)	Natural Gas (Therms/Year)	Propane (Gallons/Year)	Estimated Operating Cost**
NPE-180A-NG	Yes	Yes	Yes	Yes	6678380	Yes	0.97	0.96	3.8	154		\$168
NPE-180A-LPG	Yes	Yes	Yes	Yes	6678380	Yes	0.97	0.96	3.8		169	\$407
NPE-210A-NG	Yes	Yes	Yes	Yes	6678381	Yes	0.97	0.96	4.4	154		\$168
NPE-210A-LPG	Yes	Yes	Yes	Yes	6678381	Yes	0.97	0.96	4.4		169	\$407
NPE-240A-NG	Yes	Yes	Yes	Yes	6678382	Yes	0.97	0.96	4.9	154		\$168
NPE-240A-LPG	Yes	Yes	Yes	Yes	6678382	Yes	0.97	0.96	4.9		169	\$407
NPE-150S-NG	Yes	Yes	Yes	Yes	8235610	Yes	0.97	0.96	2.8	154		\$168
NPE-150S-LPG	Yes	Yes	Yes	Yes	8235610	Yes	0.97	0.96	2.8		169	\$407
NPE-180S-NG	Yes	Yes	Yes	Yes	6478771	Yes	0.99	0.97	3.9	151		\$165
NPE-180S-LPG	Yes	Yes	Yes	Yes	6478771	Yes	0.99	0.97	3.9		166	\$400
NPE-210S-NG	Yes	Yes	Yes	Yes	6478772	Yes	0.99	0.97	4.6	151		\$165
NPE-210S-LPG	Yes	Yes	Yes	Yes	6478772	Yes	0.99	0.97	4.6		166	\$400
NPE-240S-NG	Yes	Yes	Yes	Yes	6478773	Yes	0.99	0.97	5.1	151		\$165
NPE-240S-LPG	Yes	Yes	Yes	Yes	6478773	Yes	0.99	0.97	5.1		166	\$400

*Note all NPE Models are field convertible from NG to LP gas.

**Based on a national average natural gas cost of \$1.09/therm, propane cost of \$2.41/gallon.

Warranty Package

	Labor	Parts	Heat Exchanger
Residential	1 Year	5 Year	15 Year
Commercial	1 Year	3 Year	8 Year

Product Features



2" PVC venting up to 60'



1/2" gas pipe capability up to 24'



Dual stainless steel heat exchangers



Field gas convertibility



Exclusive **ComfortFlow**[®] Recirculation Available on "A" Models

Temperature Rise Chart

Temp Rise (Degrees)	150 Series GPM (Gallons per Minute)	180 Series GPM (Gallons per Minute)	210 Series GPM (Gallons per Minute)	240 Series GPM (Gallons per Minute)
30°F	6.8	8.4	10.1	11.2
35°F	6.8	8.4	10.1	11.2
40°F	5.9	7.3	8.7	9.7
45°F	5.2	6.5	7.8	8.6
50°F	4.7	5.8	7.0	7.8
55°F	4.3	5.3	6.3	7.1
60°F	3.9	4.9	5.8	6.5
65°F	3.6	4.5	5.4	6.0
70°F	3.4	4.2	5.0	5.5
75°F	3.1	3.9	4.7	5.2
80°F	2.9	3.6	4.4	4.8
85°F	2.8	3.4	4.1	4.6

Dimensions

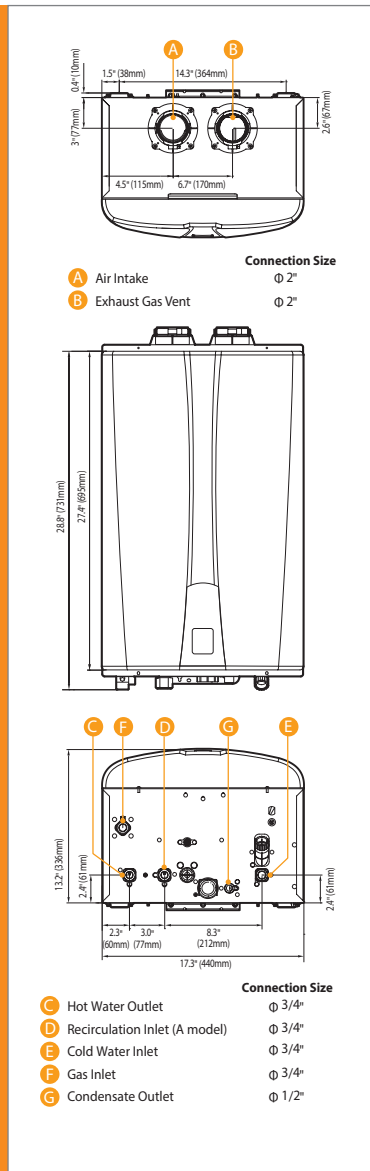

Specifications

Item	Model							
	NPE-150S	NPE-180A	NPE-180S	NPE-210A	NPE-210S	NPE-240A	NPE-240S	
Heat Capacity (input)	Natural Gas	18,000 120,000 BTU/H	15,000–150,000 BTU/H		19,900–180,000 BTU/H		19,900–199,900 BTU/H	
	Propane Gas	15,000–150,000 BTU/H		19,900–180,000 BTU/H		19,900–199,900 BTU/H		
Efficiency Ratings	UEF (for NG & LP)	0.96	0.96	0.97	0.96	0.97	0.96	0.97
	EF (Canada) (for NG&LP)	0.97	0.97	0.99	0.97	0.99	0.97	0.99
Flow Rate (DHW)	35°F (19°C) Temp Rise	6.8 GPM (26 L/m)	8.4 GPM (32 L/m)		10.1 GPM (38 L/m)		11.2 GPM (42 L/m)	
	45°F (25°C) Temp Rise	5.3 GPM (20 L/m)	6.5 GPM (25 L/m)		7.8 GPM (30 L/m)		8.7 GPM (33 L/m)	
	67°F (36°C) Temp Rise	3.2 GPM (12 L/m)	4.3 GPM (16 L/m)	4.2 GPM (16 L/m)	5.0 GPM (19 L/m)	5.2 GPM (20 L/m)	5.6 GPM (21 L/m)	5.7 GPM (22 L/m)
Dimensions	17.3"(W) x 27.4"(H) x 13.2"(D)							
Weight	55lbs (25kg)	75lbs (34kg)	67lbs (30kg)	82lbs (37kg)	75lbs (34kg)	82lbs (37kg)	75lbs (34kg)	
Installation Type	Indoor or Outdoor Wall-Hung							
Venting Type	Forced Draft Direct Vent							
Ignition	Electronic Ignition							
Water Pressure	15–150 PSI							
Natural Gas Supply Pressure (from source)	3.5 in WC-10.5 in WC							
Propane Gas Supply Pressure (from source)	8 in WC-13 in WC							
Natural Gas Manifold Pressure (min-max)	-0.04 in WC -0.38 in WC	-0.04 in WC to -0.84 in WC		-0.05 in WC to -0.36 in WC		-0.05 in WC to -0.58 in WC		
Propane Gas Manifold Pressure (min-max)	-0.04 in WC -0.42 in WC		-0.05 in WC to -0.50 in WC		-0.10 in WC to -0.66 in WC		-0.10 in WC to -0.78 in WC	
Minimum Flow Rate	0 GPM (0 L/m) for "A" models / 0.5 GPM (1.9 L/m) for "S" models							
Connection Sizes	Cold Water Inlet	3/4 in NPT						
	Hot Water Outlet	3/4 in NPT						
	Gas Inlet	3/4 in NPT						
Power Supply	Main Supply	120V AC, 60Hz						
	Maximum Power Consumption	200W (max 2A), 350W (max 4A) with external pump connected						
Materials	Casing	Cold Rolled Carbon Steel						
	Heat Exchangers	Primary Heat Exchanger: Stainless Steel Secondary Heat Exchanger: Stainless Steel						
Venting	Exhaust	2" or 3" PVC, CPVC, Polypropylene / 2" or 3" Special Gas Vent Type BH (Class II, A/B/C)						
	Intake	2" or 3" PVC, CPVC, Polypropylene / 2" or 3" Special Gas Vent Type BH (Class II, A/B/C)						
	Vent Clearances	0" to combustibles						
Safety Devices	Flame Rod, APS, Ignition Operation Detector, Water Temperature High Limit Switch, Exhaust Temperature High Limit Sensor, Power Surge Fuse							

Accessories

Navien reserves the right to change specifications at any time without prior notice

ComfortAir+ Kit AHU Optimizer PNBD-000001	On Demand Control Kit PZZZ-00046 Wall Plate GXXX001427 Push Button GXXX001426	PeakFlow™ Replacement Media GXXX001326 GXXX001327	Plumb Easy Valve 3/4" with Relief Valve 30009323A	Plumb Easy Valve 3/4" with Relief Valve - designed to work with pipe cover 30012581A	Vent Cap NPE Series 30010604A	Pipe Cover NPE Series 30012634A Use with Isolation Valves 30012581A
Residential Neutralizer (1 unit) GXXX001322 Replacement Media GXXX001323	Light Commercial Neutralizer (up to 6 units) GXXX001324 Replacement Media GXXX001328	Commercial Neutralizer (up to 16 units) GXXX001325 Replacement Media GXXX001329	Cascade Cable GXXX000546	Remote Controller 30009757A	NPE External Pump Wire GXXX001319	2" and 3" Wall Flange and Vent Terminator Kit 2": 30010747A 3": 30003873B



800.519.8794 | Navien.com

THE LEADER IN CONDENSING TECHNOLOGY

NPEGQF001-1508