

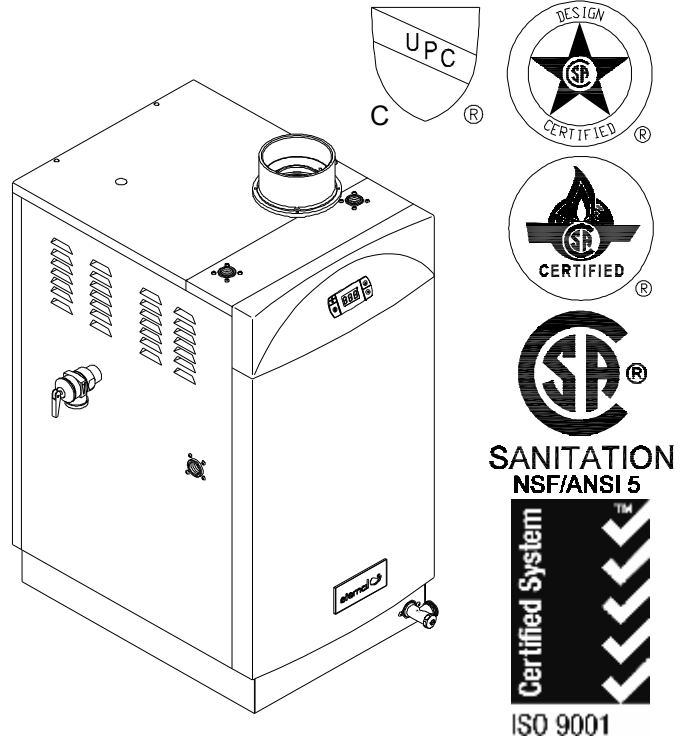

OPERATOR'S MANUAL

Natural Gas (NG)-Factory Default
 Liquid Propane Gas (LPG)-Optional Conversion

Model GU32 / 501(11,12,21,22)1321
 Model GU28 / 501(11,12,21,22)1281 (Optional)
 Model GU26 / 501(11,12,21,22)1261
 Model GU20 / 501(11,12,21,22)1201 (Optional)



Service Information Center:

Call us first if you have any questions with this product. We can help you with questions about assembly and Water Heater operation or if there are damaged or missing parts when you unpack this unit from the shipping box. Please call before returning to the store.

1-866-946-1096
 8am-4:30pm CST, Monday through
 Friday

IMPORTANT:

- **Only specially trained and authorized personnel are permitted to service this water heater.**
- **NOTE TO ASSEMBLER / INSTALLER:**
 Leave this manual with the consumer.
- **NOTE TO CONSUMER:**
 Keep this manual for future reference.
- **RECORD YOUR SERIAL # _____**
 (see silver CSA label on Gas Water Heater)

WARNING

Read this Operator's Manual carefully and be sure your Water Heater is properly assembled, installed and maintained. Failure to follow these instructions exactly could result in a fire or explosion, serious bodily injury and/or property damage.

Do not store or use gasoline or other flammable vapors and liquids in the vicinity of this or any other appliance.

WARNING

WHAT TO DO IF YOU SMELL GAS

1. Do not try to light any appliance.
2. Do not touch any electrical switch; do not use any phone in your building.
3. Immediately call your gas supplier from a neighbor's phone. Follow the gas supplier's instructions.
4. If you cannot reach your gas supplier, call the fire department.

WARNING

California Proposition 65 lists chemical substances known to the state to cause cancer, birth defects, death, serious illness or other reproductive harm. This product may contain such substances, be their origin from fuel combustion (gas, oil) or components of the product itself.

Table of Contents

Primary Safety Warning.....	1-3
Pre-Installation Instructions.....	3
Parts Diagram and List for GU28/GU32....	4-5
Parts Diagram and List for GU20/GU26....	6-7
Operating Instructions.....	8-9
Use & Care Instructions	
• Maintenance and Service.....	10
• Troubleshooting.....	11
• Specifications.....	12
• Installation.....	13-24
• Gas Supply Piping.....	25
• Water Supply Connection.....	26-27
• Electrical Connection.....	28-30
• Liquid Propane Gas Conversion.....	31-32
• Plumbing Diagrams.....	33-34
• Warranty Terms.....	35

WARNING

If you do not follow these instructions exactly, a fire or explosion could result causing property damage, personal injury or loss of life.

WARNING

Do not install water heater where flammable products will be stored.

Read and follow the water heater warnings and instructions. If the operator's manual is missing, contact the retailer or manufacturer.

DANGER

- Hot water temperature over 125°F can cause severe burns instantly or death from scalding.
- Children, disabled and elderly are at the highest risk of being scalded.
- Temperature limiting valves are available, ask your service professional.
- Check the temperature of the running hot water by hand before taking a shower.
- Check to see that the gas supplied matches the gas type on the rating plate.

WARNING

If you detect abnormal combustion or abnormal odors, or an earthquake, tornado or fire:

1. Turn off the hot water supply at the faucet.
 2. Turn off the power to the hot water heater by unplugging.
 3. Turn off gas and water at the manual shut-off valves.
 4. Consult the nearest service personnel.
- This will help prevent fire, electrical shock or damage to the unit.

WARNING

- DO NOT place combustible chemicals or materials such as laundry, newspapers, hair spray, spray detergent, oil, gasoline, benzene etc., near the water heater or the exhaust vent terminal.
- LEAVE the proper clearance between the water heater and nearby objects (trees, timber, boxes and flammable materials etc...)
- BE SURE to electrically ground the unit.
- DO NOT touch the power cord with wet hands.
- KEEP power cord free of dust.
- DO NOT use a broken or modified power cord.
- DO NOT bind, bend or stretch power cord.
- DO NOT connect the water heater to a solar water heater.

WARNING

Never use this hot water heater unless it is completely filled with water.

To prevent damage to the tank, the tank must be filled with water. Water must be running from the hot water faucet before turning the main gas valve to the water heater to "ON".

Turning Off The Appliance:

1. Turn off all electrical power by unplugging the power cord from the outlet if service is to be performed.
2. Turn the gas shut-off valve located separately of the water heater to the OFF position.

Pre-Installation Instructions for Your Safety



WARNING



If you do not follow these instructions exactly, a fire or explosion could result causing property damage, personal injury or loss of life.

Installation Codes

- The installation must conform with local codes or, in the absence of local codes, with National Fuel Gas Code, ANSI Z223.1/NFPA 54.
- Properly ground the unit in accordance with all local codes or in the absence of local codes, with the National Electrical Codes, ANSI/NFPA 70.
- A. This water heater does not have a pilot. It is equipped with an ignition device that automatically lights the burner. Do not try to light the burner by hand.
- B. **BEFORE OPERATION** smell all around the water heater area for evidence of leaking gas. Be sure to smell next to the floor because gas is heavier than air and will settle on the floor.

WHAT TO DO IF YOU SMELL GAS

Do not try to light any appliance.

Do not touch any electrical switch.

Do not use any phone in your building.

- Immediately call your gas supplier from a neighbor's phone. Follow the gas supplier's instructions.
- If you cannot reach your gas supplier, call the fire department.

- C. Use only your hand to turn the gas valve knob. Never use tools. If the knob will not turn by hand, don't try to repair it. Call a qualified service technician. Force or attempted repair could result in a fire or explosion.
- D. Do not use this water heater if any part has been under water. Immediately call a qualified service technician to inspect the water heater and to replace any damaged parts.

OPERATION INSTRUCTION

1. **STOP!** Read this safety information above and in this Operators Manual.
2. Turn off all electrical power to the water heater.
3. Do not attempt to light the burner by hand.
4. Turn the manual gas valve located on the outside of the unit to the off position.
5. Wait five (5) minutes to clear out any gas. If you smell gas, **STOP!** Follow "**B**" in the safety information above. If you don't smell gas, go to next step.
6. Turn the manual gas valve located on the outside of the unit to the ON position.
7. Turn on all electrical power to the water heater.
8. If the water heater will not operate, follow the instruction "To Turn Off Gas Water Heater" and call your service technician or gas supplier.

TO TURN OFF GAS TO WATER HEATER

1. Turn off all electrical power to the water heater if service is to be performed.
2. Turn the manual gas valve located on the outside of the unit clockwise to the off position.

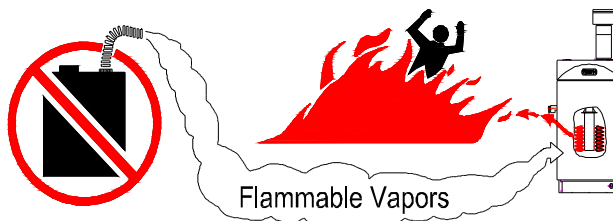

Vapors from flammable liquids will explode and catch fire causing death or severe burns

Do not use or store flammable products such as gasoline, solvents or adhesives in the same room or area near the water heater.

Keep flammable products

1. Far away from water heater
2. In approved containers
3. Tightly closed
4. Out of children's reach

Vapors

1. Cannot be seen
2. Vapors are heavier than air
3. Go a long way on the floor
4. Can be carried from other rooms to the main burner by air currents

WARNING: Do not install water heater where flammable products will be stored.

Read and follow the water heater warnings and instructions. If the operator's manual is missing, contact the retailer or manufacturer.

The hot water outlet temperature of the water heater is factory set 122° F (50° C).

WARNING: Use this water heater at your own risk. The set outlet water temperature can cause severe burns instantly or death from scalds. Test the water before bathing or showering. Do not leave children or the infirm without supervision.

Parts Diagrams for Model GU28,32 / 501(11,12,21,22)1(28,32)1

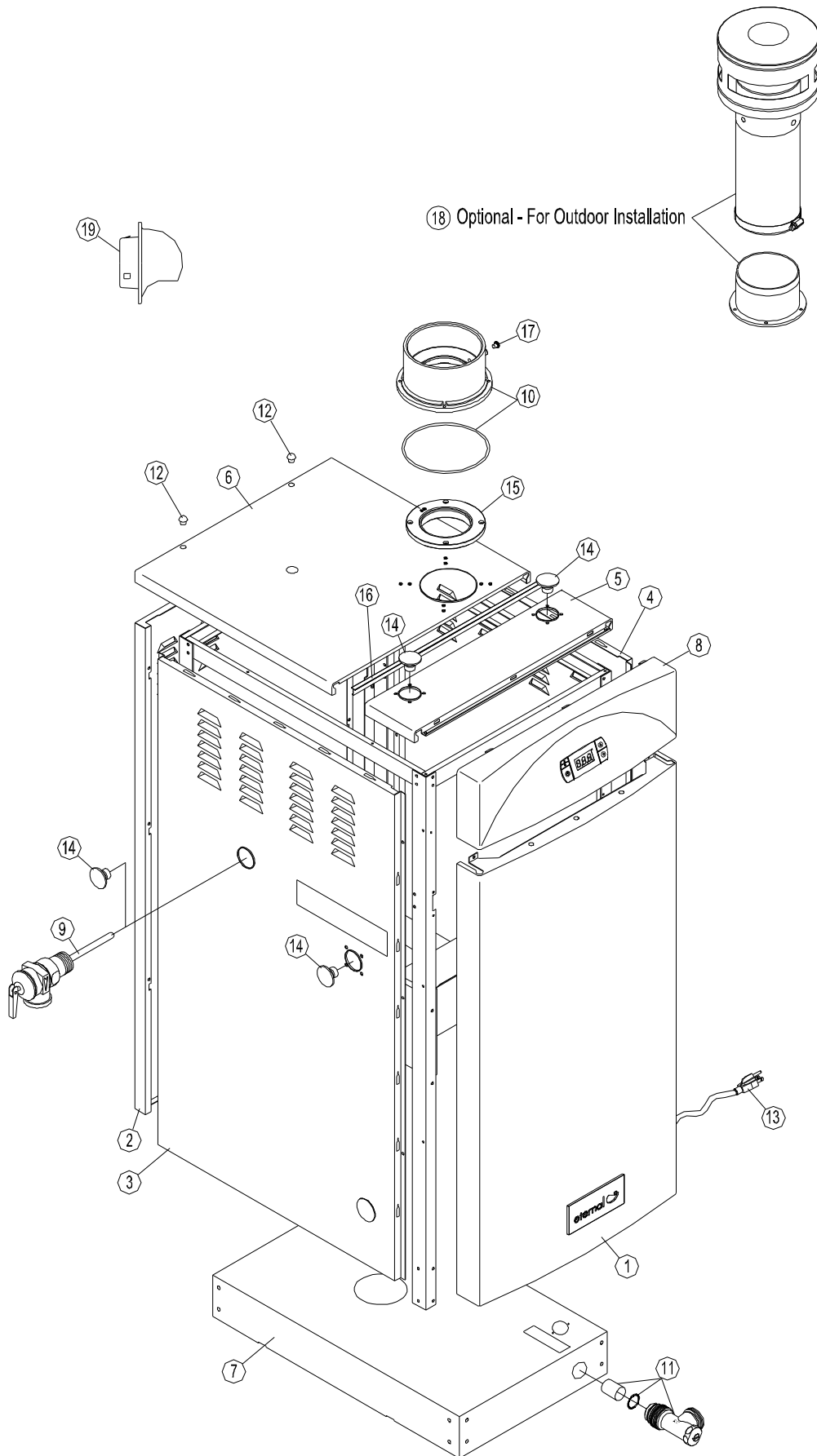

Parts List for Model GU28,32 / 501(11,12,21,22)1(28,32)1

KEY	DESCRIPTION	Part #	QTY
1	Panel, Front	302040001	1
2	Panel, Rear	302040002	1
3	Panel, Left	302040003	1
4	Panel, Right	302040004	1
5	Panel, Top/Front	301040005	1
6	Panel, Top/Rear	301040006	1
7	Panel, Bottom	151010009	1
8	Control Panel Assembly	301080170	1
9	Temperature and Pressure Relief Valve	194010281	1
10	Exhaust Collar Assembly	301070230	1
11	Drain Valve Assembly	305070273	1
12	Plug	601020001	2
13	Power Wire Assembly	192010143	1
14	Water Fitting Cap	155010059	4
15	Exhaust Flange	307040540	1
16	Packing, Top	152010227	1
17	Drain Cap	155010288	1

Optional Parts For Outdoor Model

KEY	DESCRIPTION	Part #	QTY
18	Vent Cap Assembly (Exhaust Top Included)	301080190	1

Optional Parts For Horizontal Venting Termination

KEY	DESCRIPTION	Part #	QTY
19	Side Vent Terminator	151010187	1

Parts Diagrams for Model GU20,26 / 501(11,12,21,22)1(20,26)1

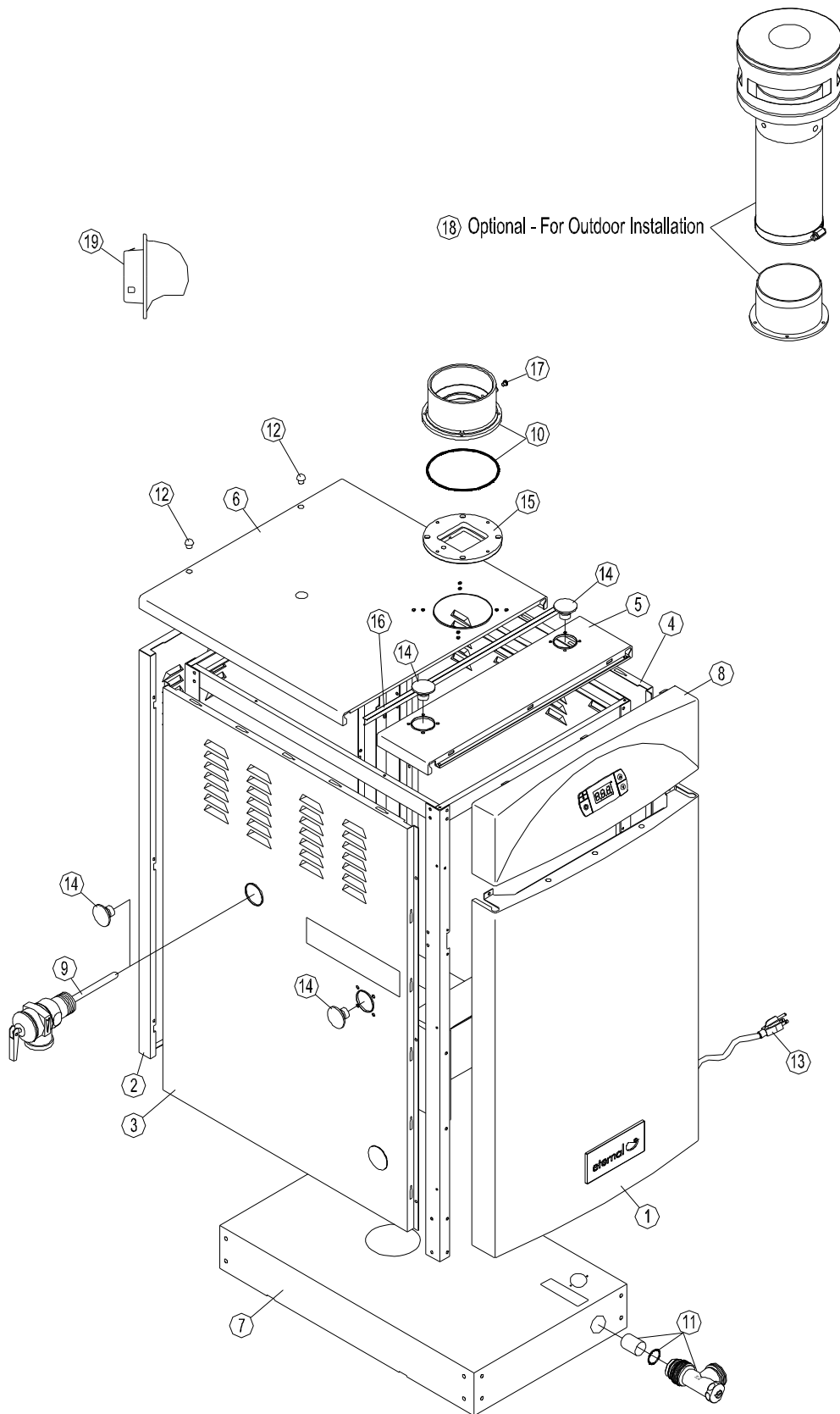

Parts List for Model GU20,26 / 501(11,12,21,22)1(20,26)1

KEY	DESCRIPTION	Part #	QTY
1	Panel, Front	301040001	1
2	Panel, Rear	301040002	1
3	Panel, Left	301040003	1
4	Panel, Right	301040004	1
5	Panel, Top/Front	301040005	1
6	Panel, Top/Rear	301040006	1
7	Panel, Bottom	151010009	1
8	Control Panel Assembly	301080170	1
9	Temperature and Pressure Relief Valve	194010281	1
10	Exhaust Collar Assembly	301070230	1
11	Drain Valve Assembly	305070273	1
12	Plug	601020001	2
13	Power Wire Assembly	192010143	1
14	Water Fitting Cap	155010059	4
15	Exhaust Flange	153010226	1
16	Packing, Top	152010227	1
17	Drain Cap	155010288	1

Optional Parts For Outdoor Model

KEY	DESCRIPTION	Part #	QTY
18	Vent Cap Assembly (Exhaust Top Included)	301080190	1

Optional Parts For Horizontal Venting Termination

KEY	DESCRIPTION	Part #	QTY
19	Side Vent Terminator	151010187	1

Operating Instructions

STARTING THE SYSTEM

For your safety, read before operating

- This water heater does not have a pilot. It is equipped with an ignition device which automatically lights the burner. Do not try to light the burner manually.
- Before operating, make sure that a gas leak is not evident by smelling the area around the unit. Be sure to smell next to the floor because gas is heavier than air and will settle on the floor.
- Use only hand to turn the gas valve knob. Never use tools. If the knob will not turn by hand, do not try to repair it, call a qualified service technician. Force or attempted repair could result in a fire or explosion due to the gas leakage.
- Do not use this water heater if any part has been under water. Immediately call a qualified service technician to inspect the water heater and to replace any parts that have been under water.
- Do not install the unit standing directly on combustible surface.
- WHAT TO DO IF YOU SMELL GAS**
 - Do not try to light any appliance.
 - Do not touch any electrical switch.
 - Do not use any phone in your building.
 - Immediately call your gas supplier from a neighbor's phone. Follow the gas supplier's instructions.
 - If you cannot reach your gas supplier, call the fire department.

STARTING UP

Once the unit has been properly installed, check the gas and water connections for leaks.

Check for proper ventilation and combustible air supply to the water heater. Purge the gas and water lines to remove debris; then follow these steps to turn on your unit.

1. Close the manual gas shut-off valve located on the gas line.
2. Fully open the manual water shut-off valve on the water supply line.
3. To ensure complete filling of the heat exchanger tank, allow air to exit by opening the nearest hot water faucet. Allow water to run until a constant flow is obtained. This will let air out of the water heater and piping.
4. Open a hot water tap to check that water will flow to that tap. Then close the hot water tap.
5. Fully open the manual shut-off gas valve.
6. Plug in the 120 VAC/60Hz power supply to the water heater and turn on the unit.
7. Open tap and enjoy endless hot water!

NORMAL OPERATION

To turn on your water heater

1. Open a hot water tap.
2. Burner will ignite; the indicator will light on front controller.
3. Mix cold water to get the desired water temperature at tap.
4. Maximum temperature of hot outlet can be set by controller on the front of the unit.

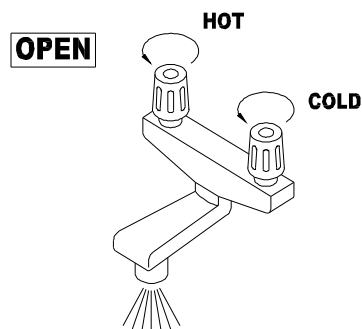

To turn off your water heater

1. Close the hot water tap and the water heater's burner will turn off automatically.

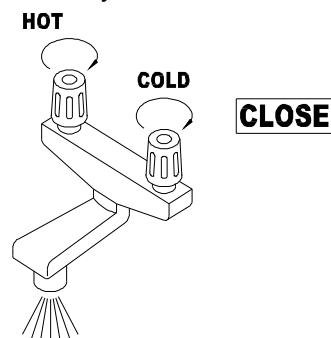

Never use this hot water heater unless it is completely filled with water.

The tank must be filled with water. Water must flow from the hot water faucet before turning "ON" gas to the water heater.



Do not drink water that has been inside the unit for extended period of time. Do not drink the first use of hot water from the unit in the morning.

How To Use The Front Control Interface

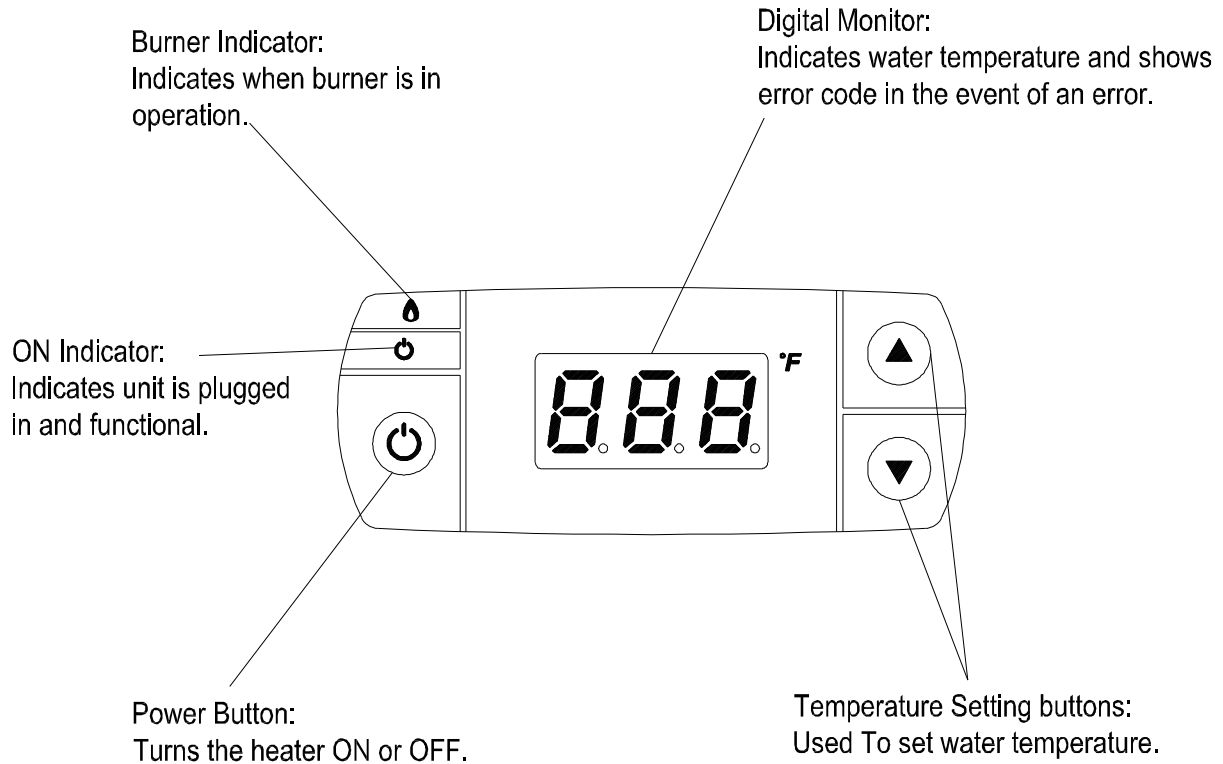

- To switch the water heater ON:** from OFF condition Press the Power Button.
 - The temperature selected will be indicated on the Digital Monitor.
 - The ON Indicator will light up.
- When running the water by opening the water tap, the water heater will start the burner automatically and the Digital Monitor will show the actual water temperature. When water taps are closed, the unit will stop the burner and the Digital Monitor will show the set temperature.

To switch the water heater OFF:

- Press the Power Button.
 - The temperature selected on the Digital Monitor will go out.
 - The ON Indicator will turn off.

To adjust water temperature:

- Press the "HOT" or "COLD" Temperature Setting Button with unit ON. (Temperature setting is only adjustable when the water heater is not in use.)
- The maximum water temperature setting can be limited by DIP switches. This manual setting overrides adjustable temperature settings on the front panel. Please call Grand Hall USA for DIP switch setting instructions if needed.

!
DANGER
!

- Hot water heater temperature over 125°F can cause severe burns instantly or death from scalding.
- Children, disabled and elderly are at the highest risk of being scalded.
- Feel water temperature before bathing or showering.
- Temperature limiting valves are available, ask a professional person.

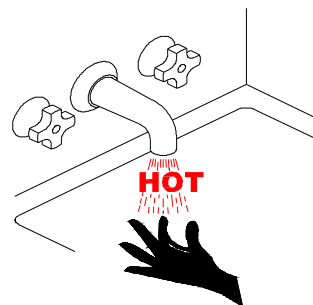

Water Temperature	Time to Produce a Serious Burn
120°F	More than 5 minutes
125°F	1.5 to 2 minutes
130°F	About 30 seconds
135°F	About 10 seconds
140°F	Less than 5 seconds
145°F	Less than 3 seconds
150°F	About 1.5 seconds
155°F	About 1 seconds

Maintenance and Service



WARNING



Turn off the electrical power supply, the manual gas control valve, and the manual water control valve before servicing.

SYSTEMS AND PARTS CHECK

The unit should be checked once a year or as necessary by a certified and trained technician. If repairs are needed, the repairs should be done by a certified and trained technician.

The following systems and parts should be checked at least once a year.

1. Venting system
 2. Burner
 3. Manual operation of the pressure relief valve to ensure correct operation.
 4. Periodic cleaning of the water strainer.
 5. Remove the thermistor from heat exchanger and check for mineral coating. A mineral coating on the thermistor requires cleaning.
- Physical Damage:** If the water heater has been subjected to fire, flood, or physical damage, turn off the manual gas shutoff valve and do not operate the water heater again until it has been checked by qualified personnel.
 - Temperature Setting:** Hotter water increases the risk of scalding injury.
 - Venting System Inspection:** A visual inspection should be made on the venting system at least once a year.
 - Be sure the venting is properly connected to prevent escape of dangerous flue gases which could cause deadly asphyxiation.
 - Obstructions could cause improper venting. The combustion and ventilation air flow must not be obstructed.
 - Damage or deterioration which could cause improper venting or leakage of combustion byproducts.
 - Clean Up:** The flue outlet and the air intake holes on the bottom sides of the water heater should be checked frequently. Clean as needed to prevent the entry of water, insects, rodents or other foreign materials such as fallen leaves and dust that could cause blockages. Do not obstruct the flow of combustion air and exhaust air flow.
 - Water Strainer:** The water strainer should be checked at least once a year. It protects valve from dirt, and pipe scale. Self-clean by opening valve or plug connected to a blow-off outlet.

- Sediment Build-up:** Unlike a typical storage tank, this heater has a self cleaning system initiated by the flow of water. Build up of sediment in faucet aerators, shower heads and screens could impair water flow and cause the water heater to deliver less than its full output, or to shut down completely. Check any of these screens or shower heads on your faucets periodically and clean as necessary.
- BURNER IGNITION:** Water heater has automatic ignition system. Once you open a hot water tap, the computer electronically ignites the burners. You can see the burner flame via flame inspection hole.

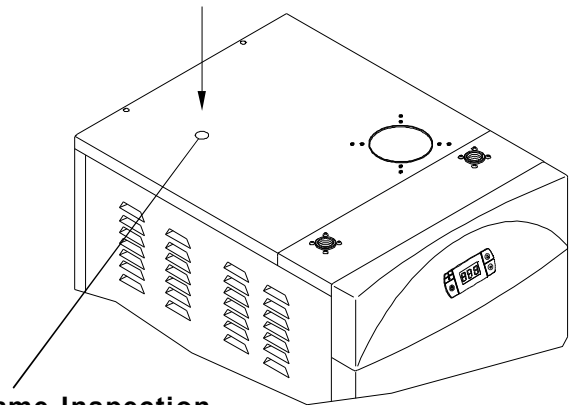

Flame Inspection Hole



CAUTION



Avoid contact with hot water released from the relief valve.

NO LUBRICATION: No lubrication is required for the water heater.

Service & Cleaning Of The Burner: Only specially trained and authorized personnel are permitted to service the burner.

Troubleshooting

TROUBLESHOOTING

This unit has the ability to check its own operation continuously. If an error occurs, a message will flash on the digital monitor of the front panel.

This assists with diagnosing the error, and may enable you to overcome a problem without a service call. Please quote the code displayed when inquiring about service.

Code Displayed	Fault	Remedy
E1	Remaining flame detected	Call service center
E2	Ignition failure	Check gas line, igniter, flame rod
E3	Weak flame or abnormal combustion	Gas line not supplying enough gas
E4 / E5	An outlet thermistor open/short	Check outlet thermistor and wiring
E6 / E7	A H/E thermistor open/short	Check H/E thermistor and wiring
E8 / E9	An inlet thermistor open/short	Check inlet thermistor and wiring
E11	A DC motor failure	Call for replacement motor
E12	Water temperature too hot	Check flow sensor or CPU
E13	No filled water in tank or pressure switch failure	Check water tank or pressures witch
E14	A controller failure concerning an inlet thermistor	Call service center
E15	A controller failure concerning a H/E thermistor	Call service center
E16	A controller failure concerning an outlet thermistor	Call service center
E17 / E18	A burner thermistor short/open	Check burner thermistor and wiring
E19 / E20	A secondary air hole thermistor short/open	Check air hole thermistor and wiring
E21	A vent condition is not normal	Check vent condition for backflow
E22	Temperature too high on a burner thermistor	Call for replacement thermistor
E24	Mixing control valve is not connected	Check mixing valve wiring
E27	Mixing control valve initialization failure	Call for replacement valve
E28	Power line of main gas valve is open	Check wiring, thermostat and fuse
E30 / E31	Rotation of a DC fan is too high/low	Call for replacement motor
E34	Carry over gas valve is not connected	Check carry over gas valve wiring
E35	Modulation gas valve is not connected	Check modulation gas valve wiring
E36	A controller failure concerning gas valve	Call service center
E37	Communication failure with SUB CPU	Call service center
E38	Subsidiary RAM failure	Call service center
E39	A controller failure concerning Subsidiary flame signal	Call service center
E40	Main RAM failure	Call service center
E41	A controller failure concerning flame signal	Call service center
E42	Main ROM failure	Call service center
E43	Main MUX error	Call service center
E46	Detection of Oxygen depletion	Call service center

NOTE: In all cases you may be able to clear the Error Message simply by turning the hot water tap OFF, then ON again. If this does not clear the Error Message, try pushing the ON/OFF button OFF, then ON again. If the Error Message still remains, contact our service center or your nearest service agent and arrange for a service call.

1-866-946-1096

8am-4:30pm CST, Monday through Friday

Eternal Hybrid Water Heater Technical Specifications

Model Name		GU20 (Optional)	GU26	GU28 (Optional)	GU32
Model Number (CSA)		501(11,12,21,22)1201	501(11,12,21,22)1261	501(11,12,21,22)1281	501(11,12,21,22)1321
Type	Installation	Indoor or Outdoor			
	Flue system	Forced Exhaust Power Vent			
	Operation	With or Without Remote Controls			
Ignition		Direct Electronic Ignition and Automatic Flame Sensing			
Gas Valve Type		Current Controlled Double Stage Negative Pressure Full Modulation Gas Valve			
Burner System		Single Orifice Fuel Injection Pre-Mixing Cylindrical Metal Fiber Infrared Burner w/Full Modulation			
Gas Input	Min	47,500 BTU/Hr			
	Max	145,000 BTU/Hr	180,000 BTU/Hr	199,000 BTU/Hr	236,000 BTU/Hr
Orifice Size	NG	7.0mm		9.0mm	
	LP	5.2mm		6.5mm	
Gas Supply Pressure	NG	3.5 - 10.5 "WC			
	LP	8.0 - 14 "WC			
Manifold Pressure	Min	0.9 "WC	0.9 "WC	0.5 "WC	0.5 "WC
	Max	1.6" WC	2.4 "WC	1.8 "WC	2.5 "WC
Maximum Valve Current		105mA	131mA	107mA	126mA
Combustion Analysis	CO	Under 100PPM			
	NOx	Under 55PPM			
	Flue Temp	Under 185F			
Operating water pressure		15 to 150Psi			
Flow Capacity Range		0.1 - 12.8gpm	0.1 - 15.8gpm	0.1 - 17.5gpm	0.1 - 20.8gpm
Water Flow Sensing		Water Flow Sensor w/Built-in Display			
Water Temperature Sensing		Tank Thermistor, Inlet Thermistor, Outlet Thermistor, Burner Thermistor, Air Thermistor			
Water Temperature Control		Simulation Feedforward and Feedback w/Electronically Controlled Mixing Valve			
Water Holding Capacity		3.8 gal		6.4 gal	
Thermal Efficiency		86%			
Temperature Settings		100,102,104,106,108,110,112,114,116,122,131,140 (default),149,158,167 (15 steps)			
Packaged Weight (lbs)		166.1		196.2	
Unit Weight (lbs)		145.6		172.9	
Maximum Noise Level		48db		60db	
Electrical Power Supply		120 Volts 60 Hz			
Electrical Consumption		Standby - 8 watts, Maximum - 84 watts		Standby - 8 watts, Maximum - 105 watts	
Package Dimensions (WxHxD)		20.5 x 38.3 x 24.8		20.5 x 45.7 x 24.8	
Unit Dimensions (WxHxD)		17.3 x 33.5 x 22.8		17.3 x 40.9 x 22.8	
Connections	Gas	3/4 inches NPT Female			
	Cold water				
	Hot water				
Safety Devices		T&P Valve, Flame Rod, Thermal Fuse (307F), Remaining Flame Detector, Fan RPM Detector, Freeze Protection (-4F), Vent Blockage Detection, Thermostat Switch (194F), Thermostat Switch (221F), Ignition Prevention, GFCI Leakage Breaker w/3A fuse, Mixing Valve, User Selectable Maximum Temperature Lock.			

Installation Preparation

PROFESSIONAL INSTALLATION REQUIRED

- Only specially trained and authorized technicians are permitted to service this water heater.

Unpacking Your Eternal Water Heater

- Unpack the unit carefully and make sure that all accessories are put aside so that they will not be lost.
 - Operator's manual
 - Warranty Card
 - Additional Parts
- Inspect the water heater for possible shipping damages.

Additional Safety Instructions

- Check the markings of the rating plate on the water heater to be certain the type of gas being furnished corresponds to what the water heater is equipped for.
- **Do not** connect this water heater to a fuel type not in accordance with the rating plate
 1. Read the Safety guidelines in the beginning of this manual.
 2. The internal computer controlled regulator is preset by the manufacturer and should not be adjusted by user.
 3. Maintain proper space around the unit for servicing. Install the unit so that it can be connected or removed easily.
 4. The electrical connection requires a means for switching off the power supply.
 5. Avoid installing the unit in an area with high levels of dust, sand, or debris. These particles may clog the air vent or impair the function of the fan, leading to improper combustion. Regular maintenance is needed.
 6. Do not install the unit where the exhaust vent is pointing into any opening in a building or where the noise may disturb neighbors.

WATER HEATER PLACEMENT

- Carefully choose the location for the new heater as placement is a very important consideration for the safety of the occupants in the building and for the most economical use of the appliance.
- Whether replacing an old water heater or putting the water heater in a new location, consider the following critical points:
 1. The location selected should be as close to the vent termination point as possible, and centered within the water piping system for best hot water delivery. All water heaters can leak. Do not install without adequate drainage provisions where water flow can cause property damage.

2. If vented through an outside wall or through the roof using 4" vent piping the total vent run cannot exceed 35 feet with one 90° elbow. If more elbows are required the venting distance must be reduced 5 feet for every 90° elbow.
3. Vent piping should slope downward towards the outside if condensate collector is not used. Horizontal runs require adequate support at 3 1/2 feet intervals and vertical runs supported at 5 feet intervals.
4. Condensation may be created at times as the combustion gases exit the vent cap. Discoloration of surfaces in proximity to the vent cap may occur.



CAUTION



Before commencing the Installation

Check that it is in accordance with relevant building and mechanical codes, as well as any local or state or federal regulations.



WARNING



- For other than direct vent appliance, the appliance must be located as close as possible to a chimney or gas vent.
- The appliance should be located in an area where leakage of the tank or connections will not result in damage to the area adjacent to the appliance or to lower floors of the structure. When such locations cannot be avoided, it is recommended that a suitable drain pan be installed under the appliance. The pan must not restrict combustion air flow.
- The minimum inlet gas pressure must be within the value specified by the manufacturer and the minimum value listed is only for the purpose of input adjustment.
- If a water heater is installed in closed water supply system, such as one having a backflow preventer in the cold water supply line and a thermal expansion tank is required, contact the water supplier or local plumbing inspector on how to control this situation.
- The Temperature and Pressure (T&P) relief valve must be certified as meeting the requirement of the Standard for Relief Valves and Automatic Gas Shut-off Devices for Hot Water Supply Systems ANSI Z21.22/CAN1-4.4. The valve must be marked with a maximum set pressure not to exceed the marked hydrostatic working pressure of the water heater (150 psi) and a discharge capacity not less than the water heater input rate as marked on the rating plate.
- For tank type water heaters, the relief valve must be installed near the hot water outlet.

T&P Valve and Exhaust Collar Installation

1. Loosen 2 screws holding the Front Panel at the bottom, push the panel down and towards yourself to remove. Take the accessory box out of the front of the unit. This box contains:

T&P Relief Valve x 1

Exhaust Collar x 1

O Ring (G95) x 1

Mesh Screen x 1

Drain Cap x 1

Self Tapping Screw (T4x16) x 5

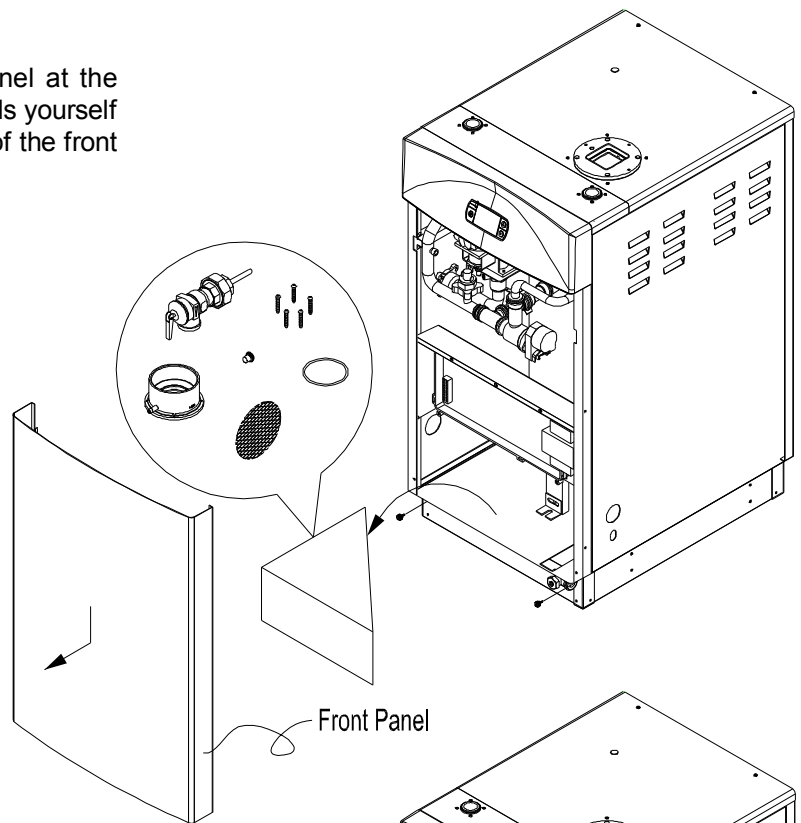

2. Attach the Front Panel and push the panel up. Secure with the previously removed screws.

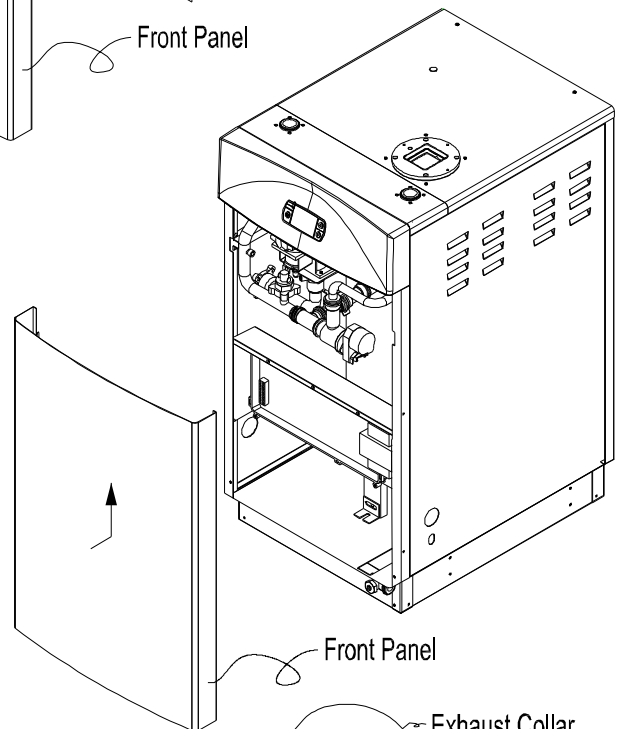

3. Prior to installing the Exhaust Collar, please secure the O-Ring between the Exhaust Flange and bottom of Exhaust Collar with T4 screws.

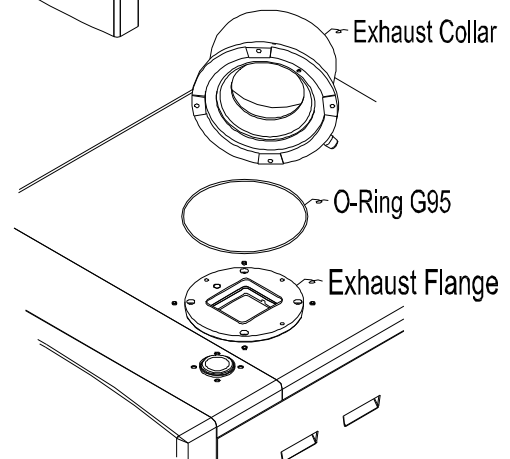

T&P Valve and Exhaust Collar Installation

4. Install the Exhaust Collar and secure with M4 screws.
5. Install the T&P Relief Valve on the side of unit. Make sure the T&P Relief is secured to prevent water leak.

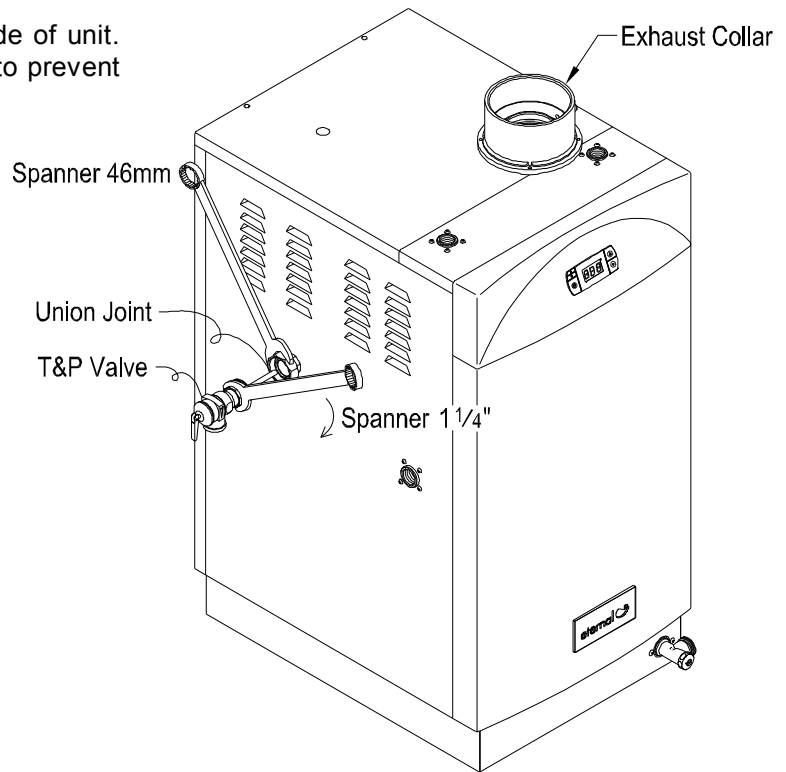

Vent Cap Installation (For Outdoor Installation)

1. Install the Vent Cap on the Exhaust Top. Secure the Vent Cap by using clamp or screw on the Exhaust Top.

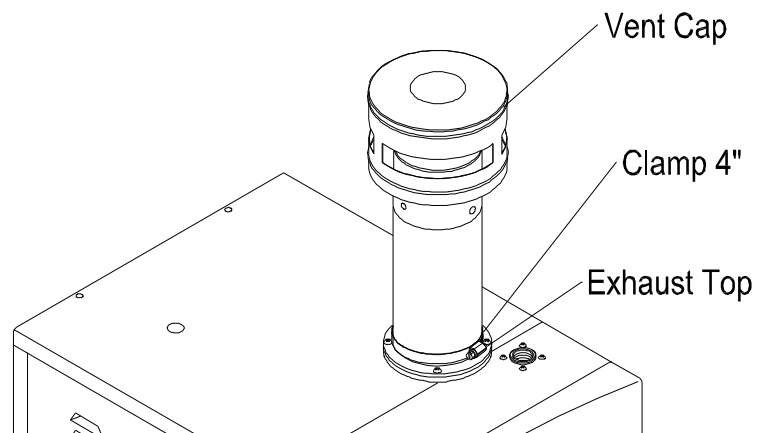

Outdoor Installation

STANDING INSTALLATION

- This unit is to be installed on a floor.
- Do not install the unit standing directly on combustible surface.

OUTDOOR INSTALLATION

Installation Codes :

Follow all local codes, or in the absence of local codes, follow the codes for installation of gas burning appliances; National fuel gas code ANSI Z221.23. For outdoor installation, do not remove the vent cap from the top of the appliance. Locate the water heater in an open, unroofed area, and maintain the following minimum clearances from combustible materials.

Clearances

	OUTDOOR	INDOOR
A - From top of water heater	24 inches	36 inches
B - From front of unit	24 inches	4 inches
C - From side wall flue or vent connector in any direction	--	6 inches
D - From back of unit	2 inches	2 inches
EL - From left side of unit(gas piping side)	12 inches	6 inches
ER - From right side of unit	2 inches	2 inches
FL - Floor	combustible	combustible

If this unit is installed under an overhang, there must be a 24" clearance from the top of the unit to the overhang, and the surrounding area must be open in front and on the sides of the unit.

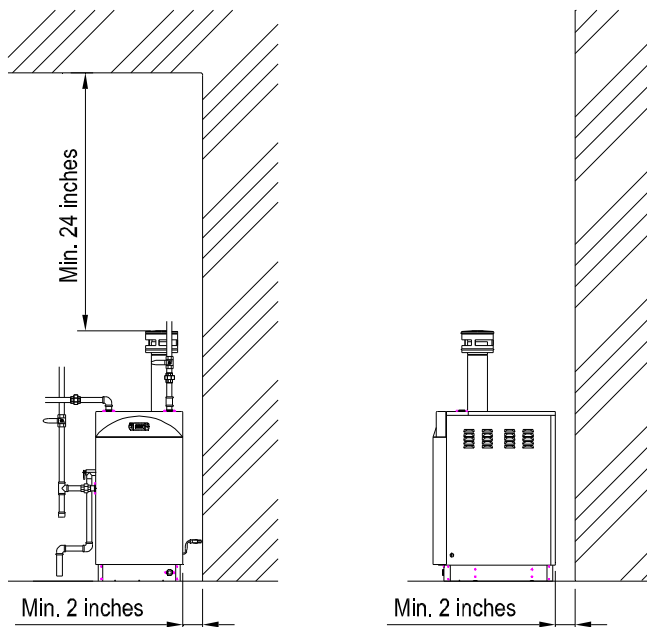

WARNING

Do not have the flue terminal pointing toward an opening into the building. Do not locate your heater in a pit or any location where gas and water can accumulate.

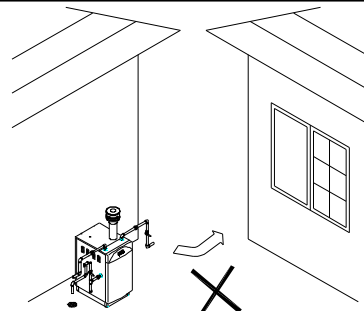

WARNING

Do not install the water heater where water, debris or flammable vapors may get into the flue terminal. This may cause damage to the water heater.

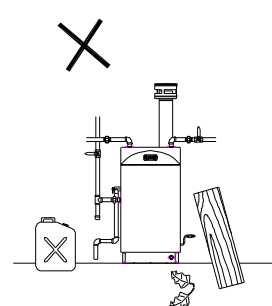

WARNING

Do not install the heater vent terminator within 4 ft. of any air intake opening into any building. Similar Canadian regulations forbid the unit from being installed within 10 ft. of any opening into any building.

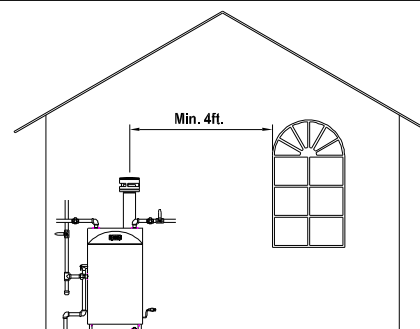

DANGER

Improper installation can cause nausea or asphyxiation from carbon monoxide and flue gases which could result in severe injury or death. For installation in altitudes above 4,500 feet, contact the manufacturer for installation instructions.

Indoor Installation

INDOOR INSTALLATION

- Install 4" vent pipe directly on flue outlet.

Combustion Air Supply:

- The water heater should be located in an area where enough air is available for proper combustion and ventilation of the surrounding area. Follow the latest edition of ANSI Z223.1 and any your local codes that are applicable.
- Eternal is a Category III vented appliance and manufacturer's ventilation specifications should be followed.
- In general these requirements specify that if the unit is installed in a confined space, there must be permanent air supply openings.

MINIMUM RECOMMENDED AIR SUPPLY TO WATER HEATER

Water heater capacity	Outside air area	Inside air area
Max. 236,000 BTU	16 sq.in.	64 sq.in.
Max. 199,000 BTU	14 sq.in.	54 sq.in.
Max. 180,000 BTU	12 sq.in.	48 sq.in.
Max. 145,000 BTU	10 sq.in.	40 sq.in.

INSTALLATION DIAGRAM

4" Category III Special Venting and PVC, CPVC, ABS Venting

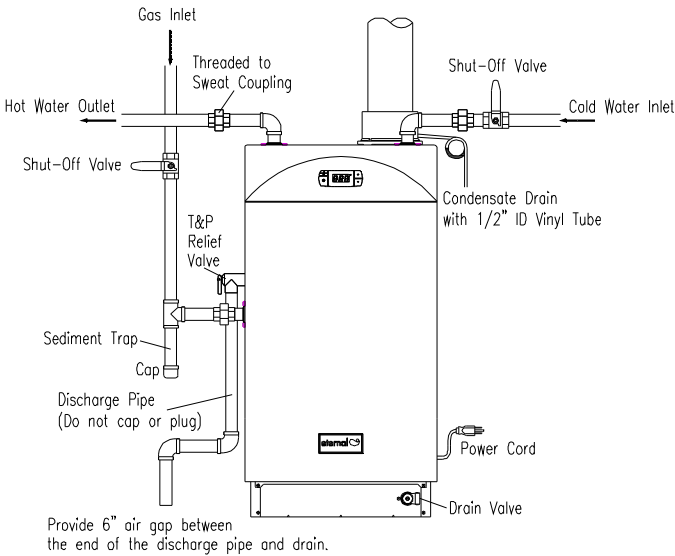

Air supply from outside building:

When combustion air is supplied directly through an outside wall such as intake louvers openings into the dwelling, each opening should give a minimum free area of one square inch per 15,000 Btu/hour of the total input ratings of all appliances in the enclosed area.

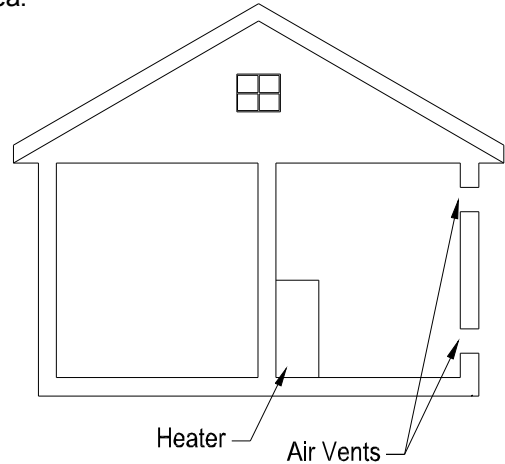

Air supply from inside building:

When combustion air is supplied from inside the building, each opening should give a minimum free area of one square inch per 3,750 Btu/hour of the total input ratings of all appliances in the enclosed area. These openings should never be less than 40 sq.in.

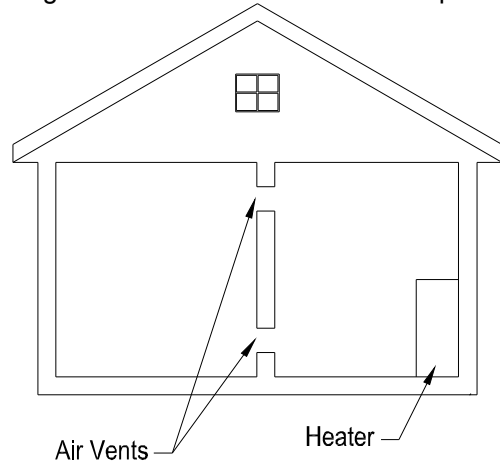

- 64sq.in. each for GU32/501(11,12,21,22)1321
- 54sq.in. each for GU28/501(11,12,21,22)1281
- 48sq.in. each for GU26/501(11,12,21,22)1261
- 40sq.in. each for GU20/501(11,12,21,22)1201

WARNING

Improper installation can cause nausea or asphyxiation from carbon monoxide and flue gases which could result in sever injury or death. For installation in altitudes above 4,500 feet, contact the manufacturer for installation.

The minimum required inside air volume should be 50 cu.ft per every 3,750 Btu/hour.

Water Heater Capacity	Minimum Required Air Volume
Max. 236,000 BTU	3,150 cu.ft
Max. 199,000 BTU	2,655 cu.ft
Max. 180,000 BTU	2,400 cu.ft
Max. 145,000 BTU	1,950 cu.ft

Mounting Procedure for Commercial / Foodservice

Description:

In compliance with NSF-5 standard, water heaters should be mounted in a way that seepage cannot accumulate under the unit. Grand Hall recommends either applying watertight caulking along the bottom edge of the unit with the floor surface, or install Eternal in conjunction with a water heater stand or platform that would raise the unit at least 6" off the floor.

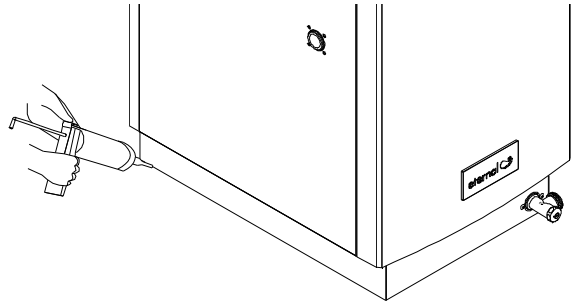

Caulking Method:

Apply caulking along the bottom edge of the unit. Make sure the caulk is water tight and applied evenly between unit and flat surface to prevent seepage from accumulating underneath the unit.

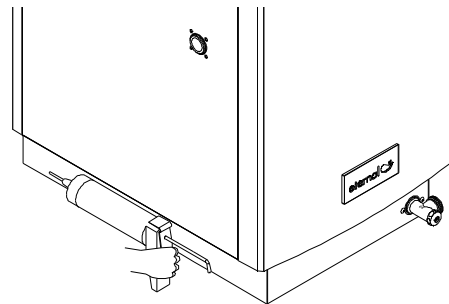

Mounting on raised platform or stand:

Install the unit on a water heater stand that raises the unit at least 6" from the floor where seepage can accumulate underneath the unit.

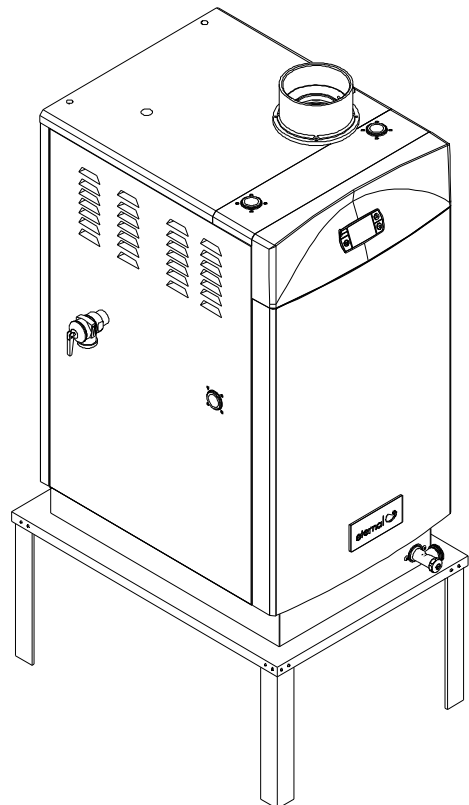

Condensate Drain Installation

CONDENSATE DRAIN REQUIREMENTS

VERTICAL TERMINATION

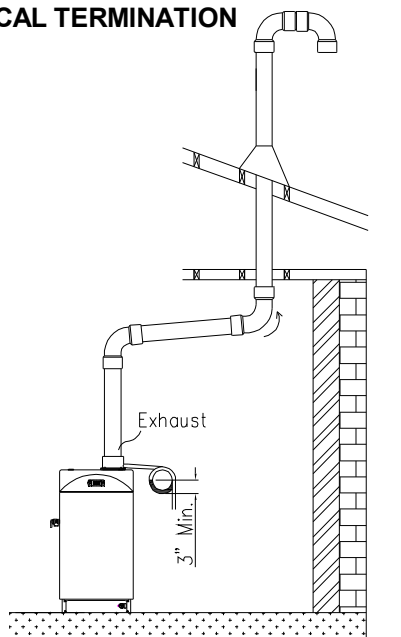

HORIZONTAL TERMINATION

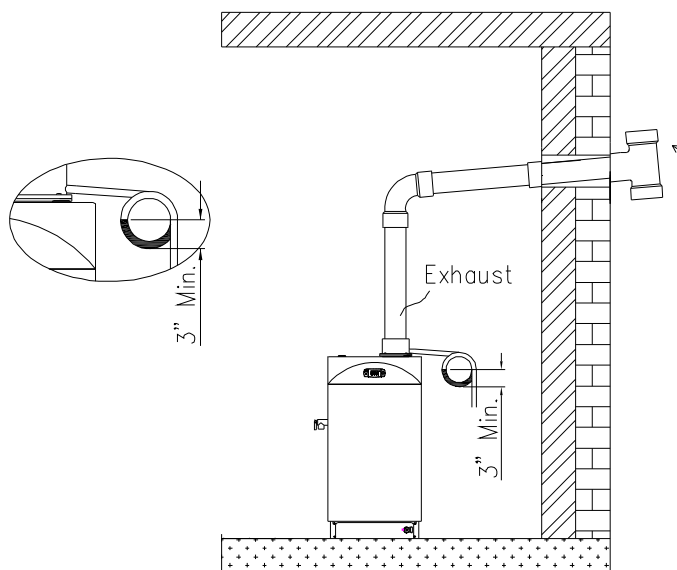

Condensate formation can occur in high efficiency power vent appliances. To prevent condensate damage, a condensate drain must be installed under the following conditions:

- All vertical terminating vent installations.
- Horizontal terminating vent installations if a vertical rise in the vent system exceeds 5 ft. If more than one elbow is used in the vertical section, a condensate collector must be used.

When the condensate collector is used, please follow these instructions.

- The Exhaust Collar of this water heater has a built-in condensate collector. Use 1/2" ID vinyl tube to connect condensate drain port. Do not use copper piping for any portion of the condensate drain.
- The condensate trap must contain a minimum of 3 inches of water.
- Dispose of condensate per local codes.

Horizontal Termination Without Using The Condensate Collector

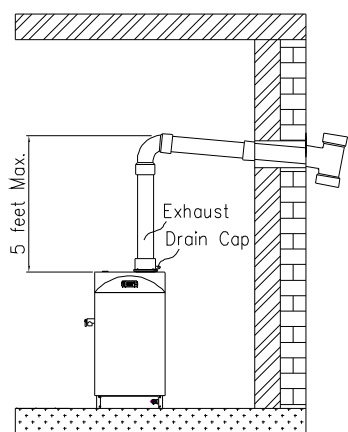
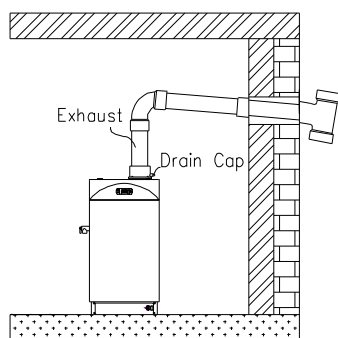

WARNING

If the condensate collector is not used, the drain pipe must be capped to prevent exhaust gases and condensate from entering the building. The Drain Cap is supplied on the appliance.

- The condensate collector must be used in horizontal terminations if a vertical rise in the vent system exceeds 5ft.
- Regions of cold climate will create more condensate in the vent system. The condensate collector should be used in cold climates.
- If more than one elbow is used in the vertical section the condensate collector must be used.

Exhaust Venting Installation

EXHAUST VENTING INSTALLATION

Exhaust Fans and Ventilation

- The water heater is equipped with a combustible air detector to measure whether there is enough air for proper combustion. If there is not, the water heater will not work until sufficient air is provided.
- Any equipment, which uses air from an enclosed space, can deplete the air from that area. This can result in exhaust flowing from the flue to the enclosed space, which could result in the accumulation of dangerous exhaust fumes in the space where the water heater is installed.
- Additional air must be supplied to compensate for any exhaust effect.
- If a fan blower is used to supply air to the water heater room, the installer should make sure it does not create drafts, which could cause unwanted shutdowns.
- If a blower is necessary to provide adequate combustion air to the water heater, a switch or equivalent device must be wired into the water heater control to prevent the water heater from firing unless the blower is operating.

VENTING INSTRUCTION

- This water heater must be vented in accordance with "Venting of Equipment" section of the latest edition of the National Fuel Gas Code, ANSI Z223.1 and all applicable local building codes.



WARNING



Improper venting of this appliance can result in excessive levels of Carbon Monoxide, which can cause severe personal injury or death.

General rules for venting system

1. Place the water heater as close as possible to the vent.
2. The vent collar on the water heater must be fastened directly to an unobstructed vent pipe.
3. Do not weld the vent pipe to the water heater collar. The weight of the stack must not rest on the water heater. The flue must be easily removable for normal service and inspection of the unit.
4. The water heater must not share common vent with a fireplace, wood stove or other appliances.
5. Avoid terminating the water heater vent near any air-conditioning or air-supply fans.
6. Avoid using an oversized vent pipe or using extremely long runs of the pipe. This may cause excessive cooling and condensation of flue exhaust gases.
7. The venting system must be installed in a manner which allows inspection during the installation of the venting pipes and joints as well as periodic inspection after installation as required by ANSI standards.

VENTING CONNECTION

- The vent system must be gas tight. All seams and joints must be sealed with silicone sealant or adhesive tape having a minimum temperature rating of 400° F.
- When installing the vent system, all applicable national and local codes must be followed. If thimbles, fire stops or other protective devices are going to be installed which will penetrate any combustible or noncombustible construction, be sure to follow all applicable national and local codes.
Fan assisted appliances: Follow the requirement as indicated in the latest edition of ANSI Z233.1/NFPA 54.
- Horizontal exhaust vent connectors must pitched downward to the terminal if condensate collector is not used, at least 1/4" per foot of length. Single wall vent connectors must be at least 6" from adjacent unprotected combustible surfaces. Joint of vent connectors should be securely fastened by sheet metal screws or other approved method.

VENTING LENGTH

- The entire vent system must not exceed the size specified in table.

Diameter	4 inches
Max. No. of Elbow	3 ea
Max. Vertical or Horizontal run in Length	40 ft

For each elbow added, deduct 5 feet from maximum vent length. For example, 30 ft. is the maximum total distance if two elbows are used.

- When the horizontal vent run exceeds 5 feet the following criteria must be observed:
 - Support the vent run at 3 feet intervals with overhead hanger.
 - Pitch down the vent run toward the vent terminal at a rate of 1/4 inch per every foot of horizontal run if condensate collector isn't used.

VENTING CLEARANCES

- 12" minimum from the ground, 9" from ceiling overhangs.
- The power vent outlet terminal shall terminate at least 36" above any forced air inlet located within 10 feet.
- The power vent outlet terminal shall terminate at least 4 feet below, 4 feet horizontally from or 1 foot above any door, window or gravity air inlet into the building.

VENTING TROUGH ROOF-CLEARANCES

- The power vent outlet terminal shall terminate at least 12" above the roof surface.
- The location selection must provide clearance for servicing and proper operation of the water heater.

Exhaust Venting Installation

This water heater must be properly vented for removal of exhaust gases to the outside atmosphere. Correct installation of the vent pipe system is mandatory for the safe and efficient operation of this water heater and is an important factor in the life of the unit.

Vent pipe installation must be performed in accordance with state and local codes, or in the absence of such, the latest edition of National Fuel Gas Code, NFPA 54/ANSI 223.1. Canadian installations must be performed in accordance with CAN/CGA-B149.

VENT PIPE MATERIAL

Eternal Hybrid Water Heater is a gas burning appliance with fan-assisted exhaust. The appliance must be vented with 4" Category III special venting, which is air tight to prevent leakage of exhaust gases.

The appliance must be vented separately from all other appliances. The following type of non-metallic vent can be used:

- PVC (schedule 40, ASTM-D1785)
- PVC-DWV (ANSI/ASTM-D2665)
- CPVC (schedule 40, ASTM-D2846)
- ABS (schedule 40, ASTM-D2661)

Sealant (silicon based) is recommended with metallic venting to ensure proper seal.

*Note : Do not use cellular foam core pipe.

VENT PIPE INSTALLATION

The following guidelines should be followed when installing the exhaust outlet piping:

- Venting should be as direct as possible with a minimum number of pipe fittings.
- Venting diameter must not be reduced unless specially noted in the installation instructions.
- Support all horizontal pipe runs every four feet according to local codes.
- Vents run through unconditioned spaces where below freezing temperatures are expected should be properly insulated to prevent freezing. For horizontal runs, wrap the vent pipe with self-regulating 3 or 5 watt heat tape. The heat tape must be U.L. listed and installed per the manufacturer's instructions.
- Do not connect this venting system with an existing vent or chimney.
- Do not connect common vent with the vent pipe of any other water heater or appliance.

The exhaust outlet piping and termination may be installed in one of the following terminations:

1. Standard Horizontal (see page 23)
2. Vertical (see page 23)

All pipe, fitting, pipe cement, primers and procedure must conform to American National Standard Institute and American Society for Testing and Materials (ANSI/ASTM) standards in the United States.

This water heater has been design certified by CSA International for use with the specified listed plastic vent pipe.

CEMENTING PVC, ABS or CPVC PIPE and FITTING

All primers, cleaners and cements must meet all local codes and applicable standards of the American Society for Testing Materials.

Before using primers, cleaners and cements, stir or shake, making sure contents are liquid. Do not use if found to be lumpy or jelly-like.

1. Cut pipe ends squarely removing all burrs and dirt.
2. Dry fit pipe and fittings to be connected for proper fit.
3. Clean pipe and fitting with a primer/cleaner.
4. Apply a thin coat of cement to fitting, avoiding pudding inside.
5. Apply a liberal coat of cement to pipe leaving no voids.
6. Quickly assemble parts while cement is fluid.
7. Push pipe completely into socket of fitting, turning as it goes until it bottoms.
8. Hold pipe and fitting together for 30 seconds. Then carefully clean off excess with a cloth. Allow connections sufficient time to cure before disturbing.
9. Remember that vent pipes must be adequately and securely supported.

CUTTING OPENING THROUGH AN OUTSIDE WALL AND TERMINATOR INSTALLATION

The 4" PVC, ABS or CPVC Schedule 40 vent pipe can be run from the water heater through the wall or from the wall to the water heater, whichever is most convenient.

The vent pipe must extend a minimum of 1.5" through the exterior wall. Note that inside collars must be slipped over the vent piping before locating the pipe through the wall.

Before securing the inside and outside collars to the wall, use a silicone sealer between pipe and opening to ensure water and air tight seal.

To prevent condensate from collecting in the venting system slope the vent at a downward pitch of 1/4" per 12 ft. with condensate trap.



NOTICE



For installations in Canada, field supplied plastic vent piping must comply with CAN/CGA B149 1 (latest edition) and be certified to the Standard For Type BH Gas Venting Systems, ULC S636 Components of this listed system shall not be interchanged with other vent systems or unlisted pipe/fittings. All plastic components and specified primers and glues of the certified vent system must be from a single system manufacturer and not intermixed with other system manufacturer's vent system parts. The supplied vent connector and vent termination are certified as part of the water heater.

Vent Pipe Installation & Terminator Position

EXHAUST VENT TERMINATOR POSITION

Area	Descriptions	Other than Direct Vent
A	Clearance above grade, veranda, porch, deck, or balcony	1 foot
B	Clearance to window or door that may be opened	4 feet from below or side opening. 1 foot from above opening
C	Clearance to permanently closed window	•
D	Vertical clearance to ventilated soffit located above the vent terminator within a horizontal distance of 2 feet (61 cm) from the center line of the terminator.	•
E	Clearance to unventilated soffit	•
F	Clearance to outside corner	•
G	Clearance to inside corner	•
H	Clearance to each side of center line extended above meter/regulator assembly	•
I	Clearance to service regulator vent outlet	•
J	Clearance to non-mechanical air supply inlet to building to the combustion air inlet to any other	4 feet from below or side opening. 1 foot from above opening.
K	Clearance to mechanical air supply inlet	3 feet
L	Clearance above paved sidewalk or paved driveway located on public property.	7 feet
M	Clearance under veranda, porch, deck, or balcony	•
• For clearances not specified in ANSI Z223.1 / NFPA 54, please use clearances in accordance with local installation codes and the requirement of the gas supplier.		

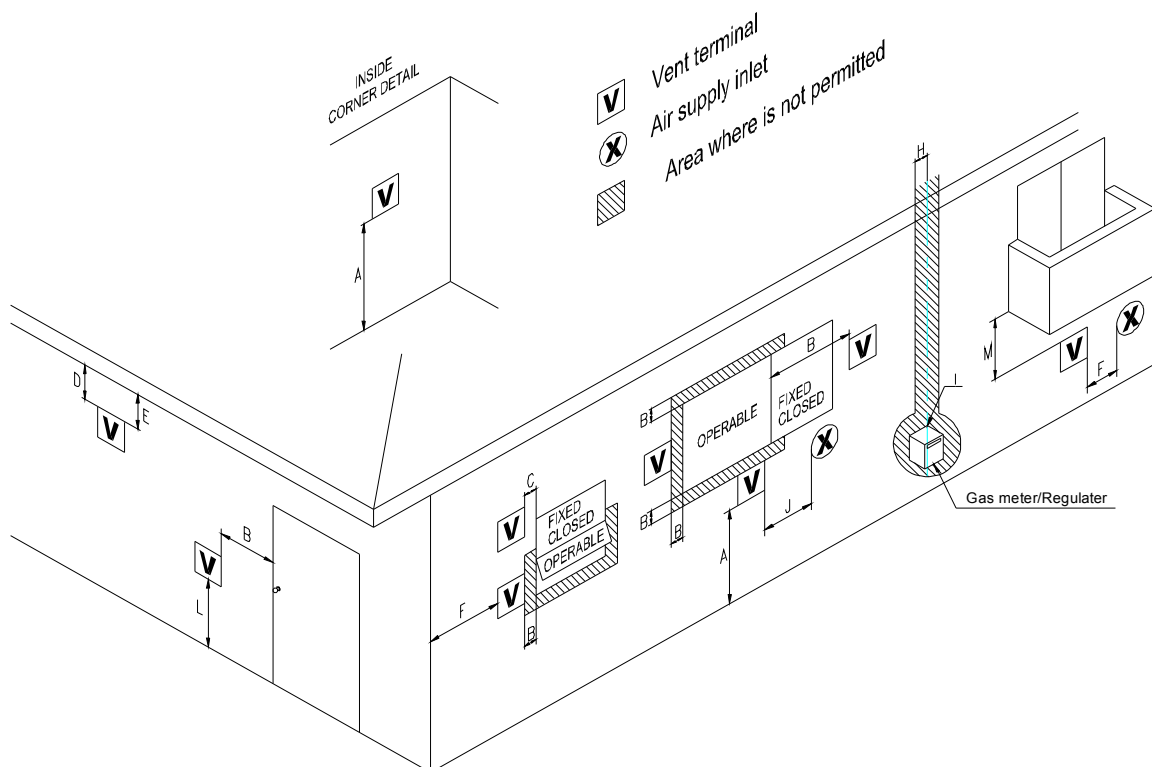

Venting Termination

Venting Material : PVC-DWV(ANSI/ASTM D2665)

VERTICAL VENTING PVC TERMINATION

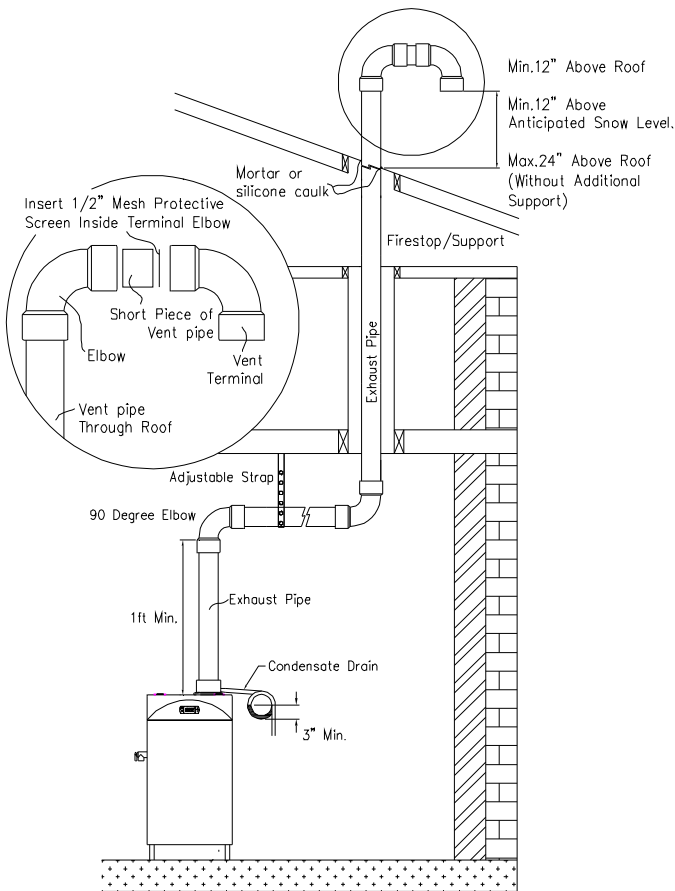

- The location of the vent terminal depends on the following minimum clearances and considerations (see illustration)
- Minimum twelve (12) inches above roof.
- Minimum twelve (12) inches above anticipated snow level.
- Maximum twenty-four(24)inches above roof level without additional support for vent.
- Four (4) feet from any gable, dormer or other roof structure with building interior access i.e. vent, window etc...
- Ten (10) feet from any forced air inlet to the building. Any fresh or make-up air inlet such as a dryer or furnace area is considered to be a forced air inlet.
- Eternal can be vented straight up and horizontal section is not required for vertical terminations.
- Condensate drain must be used in all vertical terminations.

HORIZONTAL VENTING PVC TERMINATION

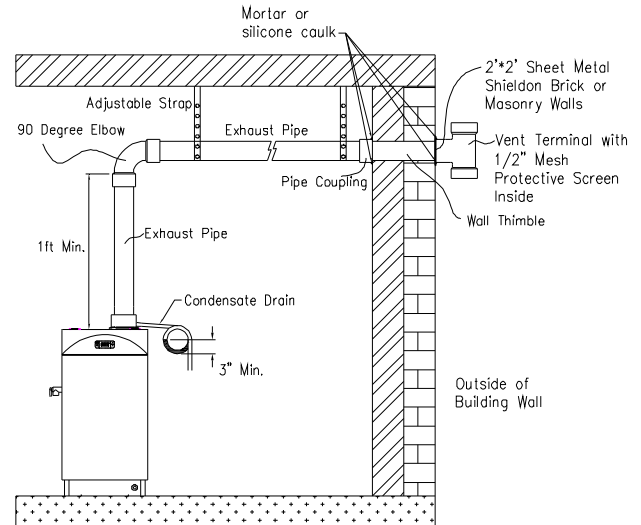

- Once the vent terminal location has been determined, make a hole through the exterior wall to accommodate the vent pipe. Vent pipe must exit exterior wall horizontally only.
- Insert a small length of vent pipe through the wall and connect the coupling as shown in above illustration.
- Place the 1/2" mesh metal screen inside the terminal fitting and connect it as shown to the vent pipe on the exterior of the building.
- Seal any opening around the vent pipe or fittings with mortar or silicone caulk as shown in above illustration.
- Complete the rest of the vent pipe installation to the water heater's exhaust top on the fan outlet.
- If necessary support horizontal run as previously mentioned.
- The dome shaped side vent terminator(151010187) is an accessory designed and provided by Grand Hall USA specifically for use with Eternal. It has been designed and thoroughly tested by our engineering staff for use with Eternal.

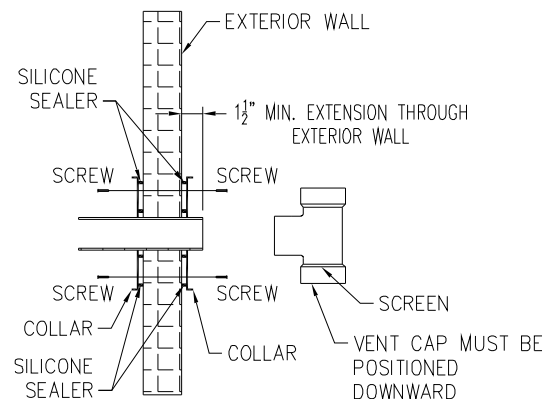

Checking Gas Combustion Specifications

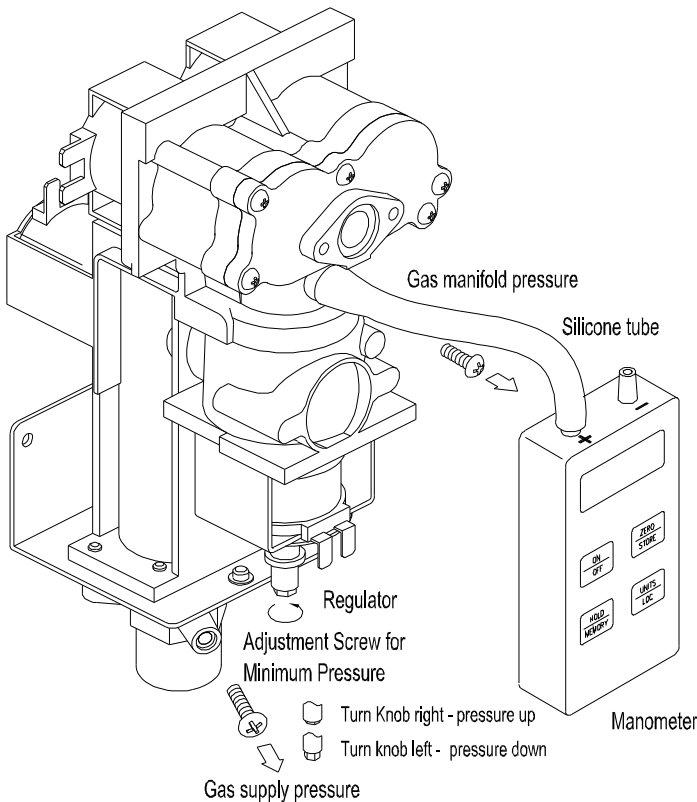

Model	Manifold Pressure		Gas Supply Pressure
	Min	Max	
GU20	0.9 "WC	1.6 "WC	NG 3.5~10.5 "WC LP 8~14 "WC
GU26	0.9 "WC	2.4 "WC	
GU28	0.5 "WC	1.8 "WC	
GU32	0.5 "WC	2.5 "WC	
GU20DV	0.9 "WC	1.6 "WC	
GU26DV	0.9 "WC	2.4 "WC	
GU28DV	0.4 "WC	1.75 "WC	
GU32DV	0.4 "WC	2.4 "WC	

Figure 1:

The gas valve is designed with both test ports for gas supply pressure to the unit, and manifold pressure. Refer to Figure 1 for locations of the test ports on the gas valve.

HOW TO CHECK GAS SUPPLY PRESSURE

1. Turn off power source and turn off gas supply to the unit.
2. Remove the front cover from the unit.
3. Remove the gas supply pressure test port screw and connect manometer to this port; turn on the gas to the water heater.
4. Turn the water heater on and open multiple taps to force unit into high fire; check gas supply pressure at the test port with a manometer with unit in high fire.

HOW TO CHECK MANIFOLD GAS PRESSURE

1. While power and gas are off to the unit, open any hot tap to flush and fill the tank completely with cold water.
2. Close the running tap and turn power and gas back on to the unit; set temperature to 131F.
3. The unit should fire up to bring the internal storage up to set temperature even without any tap open; this is standby mode.

4. Wait for 10 seconds after the start of standby mode combustion and check gas supply pressure and manifold gas pressure at the test ports with a manometer.

Check manometer reading of low fire manifold pressure against unit combustion specifications on p.12. If low fire manifold pressure needs to be adjusted, loosen the nut securing the adjustment knob on the bottom of the gas valve (refer to Figure 1) and adjust to correct setting.

NOTE: Manifold Gas Pressure should only be adjusted on low Fire

NOTE: If gas supply pressure drops below 3.5" WC unit will not have enough gas volume for max fire!

NOTE: Recirculation pump must be OFF when checking Manifold Gas Pressure.

Gas Supply Piping

GAS SUPPLY PIPING

- NOTE:** This unit needs a manual gas control valve (shut-off valve) that must be connected to the unit before the gas line.
- Check** the gas inlet pressure and the type of gas matching the rating plate located on your water heater. Also check to make sure your gas meter is capable of supplying sufficient BTU load to all appliances. Insufficient gas pressure and volume will cause your water heater to be deficient in performance and may not work properly.

Gas Piping System Codes :

Size gas piping system correctly following ANSI Z223.1/NFPA 54, or by local code.

- When measuring the inlet supply pressure, the water heater and all other gas appliances sharing the gas supply line must be firing at maximum capacity.
- Maximum gas pressures must not exceed listed value.
- Low gas pressure could be caused by an undersized gas pipe, this will cause the water heater's performance to diminish and it would not be able to reach maximum performance.

Check for Gas Leaks

- When connections are completed, check for gas leaks by applying soapy water to all gas fittings and connections. Presence of soap bubbles foaming is a sign of gas leaks.
- This appliance and its individual shut-off valve must be isolated from the gas supply piping system by unplugging the unit and turning off the main gas valve during any pressure testing of the gas supply piping system at test pressures equal to or less than 1/2 PSI.

Venting Equipment Codes

This water heater must be vented in accordance with "Venting of Equipment" section of the latest edition of the National Fuel Gas Code, ANSI Z223.1 and all applicable local building codes.

- Always use approved connectors to connect the unit to the gas line. Always purge the gas line of any debris before connecting to the heater gas inlet.

Recommended Gas Pipe Size (Diameter, for Natural Gas)	
Distance from gas meter	Pipe size(inches)
0 ft. to 20 ft.	3/4 inch
20 ft. to 60 ft.	1 inch
60 ft. to 100 ft.	1-1/4 inch

NATURAL GAS SUPPLY PIPING

Pipe size	Cubic Feet of Natural Gas													
	Length	10'	20'	30'	40'	50'	60'	70'	80'	90'	100'	125'	150'	200'
1/2"		174	119	96	82	73	66	61	56	53	50	44	40	34
3/4"		363	249	200	171	152	138	127	118	111	104	93	84	72
1"		684	470	377	323	286	259	239	222	208	197	174	158	135
1 1/4"		1404	965	775	663	588	532	490	456	428	404	358	324	278
1 1/2"		2103	1445	1161	993	880	798	734	683	641	605	536	486	416
2"		4050	2784	2235	1913	1696	1536	1413	1315	1234	1165	1033	936	801

Based on 0.60 specific gravity for natural gas at 0.5 "W.C. pressure drop DOE standard is 1100 BTU per cubic ft. of natural gas.

PROPANE GAS SUPPLY PIPING

Pipe size	K BTU of Propane Gas													
	Length	10'	20'	30'	40'	50'	60'	70'	80'	90'	100'	125'	150'	200'
1/2"		276	190	153	130	115	104	97	90	84	79	70	64	56
3/4"		568	394	316	268	238	218	197	186	174	163	147	133	112
1"		1072	733	591	505	449	410	379	347	323	308	276	253	213
1 1/4"		2206	1497	1213	1040	914	835	772	725	678	631	567	511	440
1 1/2"		3308	2300	1859	1560	1418	1276	1182	1087	1024	977	867	788	676
2"		6222	4332	3466	2993	2647	2395	2206	2048	1922	1812	1607	1496	1260

Based on 11 "W.C. supply pressure.

Water Supply Connection

WATER SUPPLY CONNECTION

- An approved manual water control valve (water shutoff valve) must be placed on the cold water supply line.
- All soldering materials and piping materials must be suitable with potable water. If the water heater is installed in a closed water system, such as one having a back flow preventer in the cold water supply line, a safety device must be provided to control thermal expansion.

Troubleshooting Thermal Expansion:

Contact the water supplier or local plumbing inspector on how to control this situation.



WARNING



Use only brass connection nipples. Connecting different types of metals with water flow creates electrolysis (battery effect). Such effect will rust the connections.

AFTER INSTALLATION

- After the water heater installation is complete, purge the water line to remove all the debris and air from the line. Failure to do so may cause damage to the heater.
- There is a wire mesh filter to trap debris from entering the heat exchanger. This will need to be cleaned periodically to prolong product life.



WARNING



Be careful not to reverse the hot water outlet and cold water supply line connections to the water heater. This will cause your heater to operate dangerously and void warranty.

Make sure the hot and cold lines are connected properly.

Typical Installation

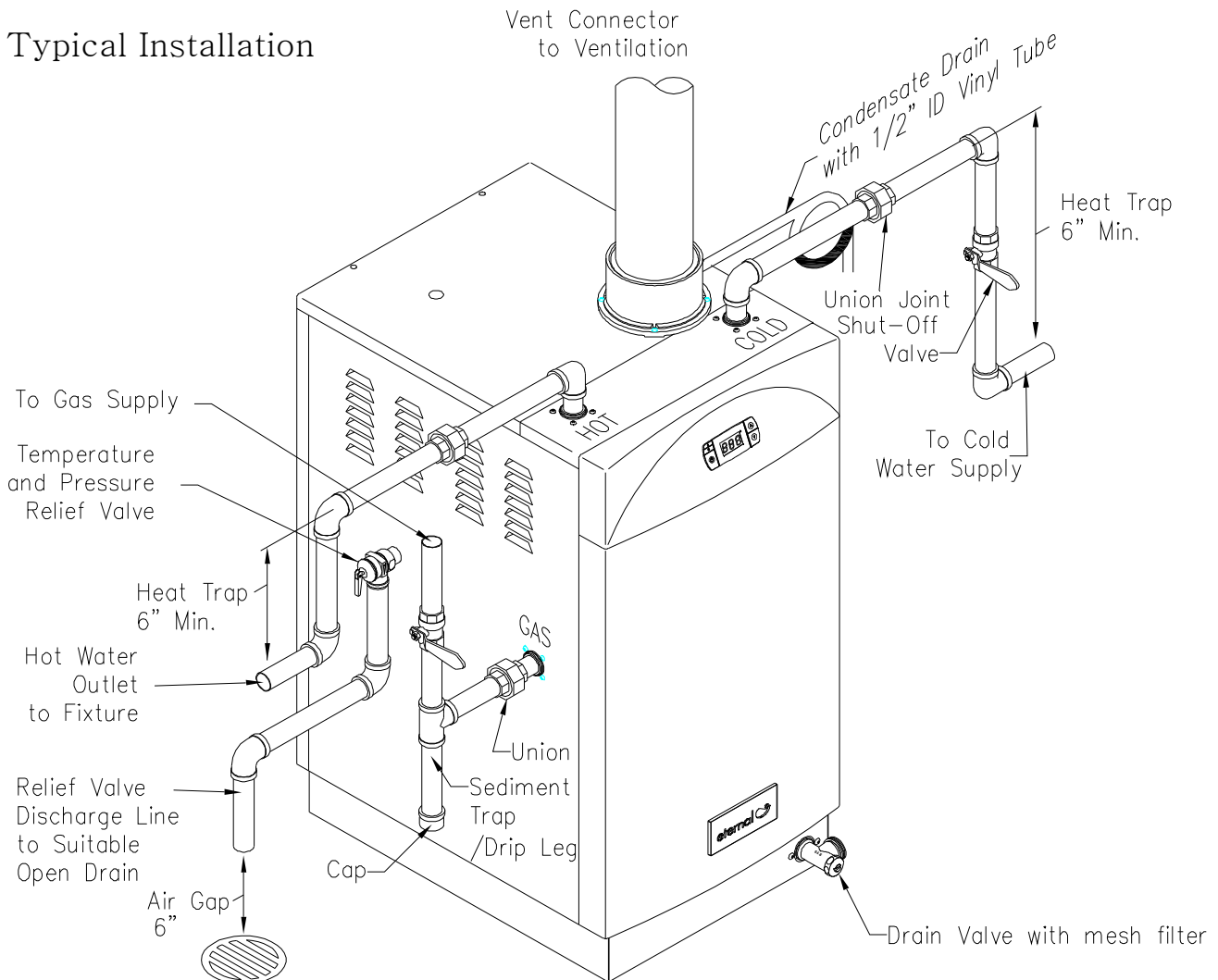

Water Supply Connection

PRESSURE RELIEF VALVE



CAUTION



The temperature-pressure relief valve should be manually opened once a year.



CAUTION



Care should be taken to ensure that:

1. No one is in front of or around the outlet of the temperature-pressure relief valve discharge line when in use.
2. If after manually opening the valve and it fails to completely reset and continues to release water, immediately close the cold water inlet to the water heater, follow the draining instructions, and replace the temperature-pressure relief valve with a new one. The discharge capacity must be at least 236,000 BTU/HR for GU32 (199,000 BTU/HR for GU28, 180,000 BTU/HR for GU26 and 145,000 BTU/HR for GU20).

FILLING THE WATER



CAUTION



Never use this hot water heater unless it is completely filled with water.

To prevent damage to the tank, the tank must be filled with water. Water must flow from the hot water faucet before turning "ON" gas to the water heater.

- To fill the water heater with water;
 - Close the water heater drain valve by turning the knob to the right. The drain valve is on the lower front of the water heater.
 - Open the cold water supply valve to the water heater.
 - To ensure complete filling of the tank, allow air to purge by opening the nearest hot water faucet. Allow water to run until a constant flow is obtained. This will let air out of the water heater and piping.
 - Check all new water piping for leaks. Repair as needed.
- Be certain there are no loose particles or dirt in the piping. Keep a copper pipe diameter at NPT 3/4 inch diameters to allow the full flow. If the hot and cold connections are reversed, the heater will not work properly and could damage the unit. Be sure to connect them correctly.

- Water pipe line joint:**
Pipe joint sealing compound or dope should be used sparingly for sealing threaded joints on metal piping having NPT tapered thread.

- Do not use glue or Teflon tape.**



CAUTION



For Installations in the State of California:

California Law requires that residential water heaters must be braced, anchored or strapped to resist falling or horizontal displacement due to earthquake motions. A brochure with generic earthquake bracing information can be obtained from: Office of the State Architect, 400P Street, Sacramento, CA 95814 or you may call 916-445-8100.



CAUTION



If local codes require the water heater to be raised 18" above the floor, please install GU20/GU26 on at least 6.5" platform. GU28/GU32 does not need to be raised as its igniters and burner are at least 18" above floor. Eternal is FVIR compliant.

DRAINING THE WATER

- Connect garden hose to the draining valve located on the bottom right of the unit.
- Open the valve by using a flat head screw driver to drain water with the hose.
- After draining the tank, turn the valve body to remove the draining valve from the unit and clean the filter.



CAUTION



Do not open the draining valve without connecting a hose so that water can be diverted to an area where water damage is not a problem. Do not remove the draining valve from the unit without first draining the tank.

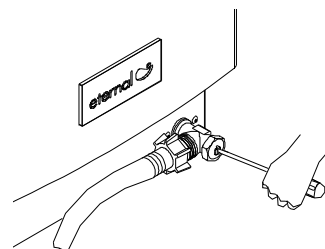

Electrical Connection

ELECTRICAL CONNECTIONS



The water heater must be electrically grounded.

Installation Codes:

Follow the requirements of the local authority having jurisdiction. In the absence of such requirements, follow the latest edition of the National Electrical Code ANSI/NFPA 70.



Do not rely on the gas or water piping to ground the metal parts of the water heater, because plastic pipe or dielectric unions may isolate the water heater electrically. Service and maintenance personnel who work on or around the water heater may be standing on wet floors, and could be electrocuted by an un-grounded water heater.



Label all wires prior to disconnection when servicing controls. Wiring error can cause improper and dangerous operation. Verify proper operation after servicing.

- The water heater requires a dedicated electrical power supply of 120 VAC/60Hz, and it must be properly grounded to function.
 - A means for switching off the 120 VAC power supply must be provided.
 - Wire the heater exactly as shown in the wiring diagram.
 - To ensure complete filling of the tank, allow air to exit by opening the nearest hot water faucet.
 - Allow water to run until a constant flow is obtained. This will let air out of the water heater and piping.
 - Check all new water piping for leaks. Repair as needed.
- Please refer to the Wiring Diagram. Note: There is a copy located on the inside of the front panel of the appliance.

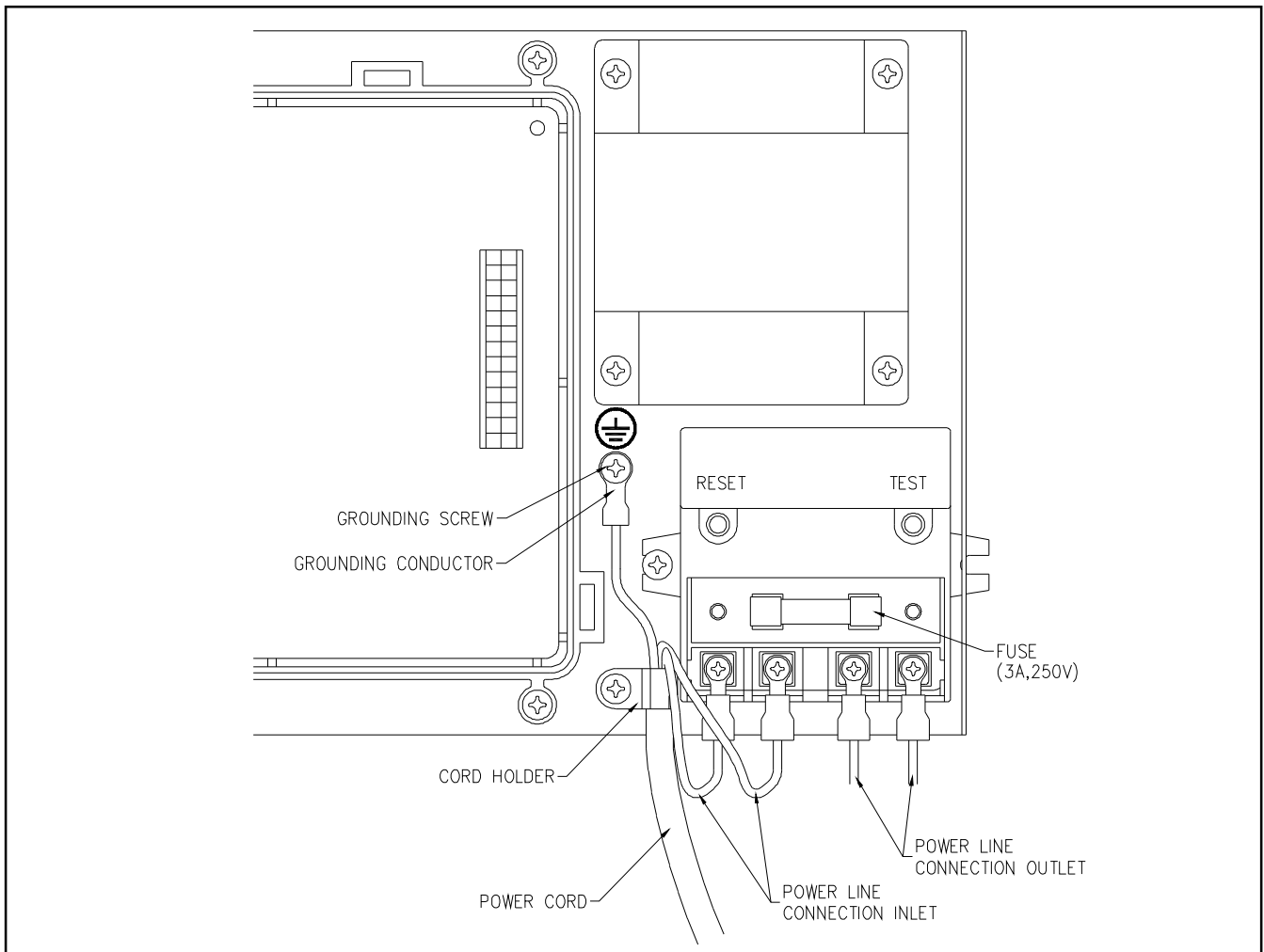

Controller DIP Switch Setting

Location of DIP Switch

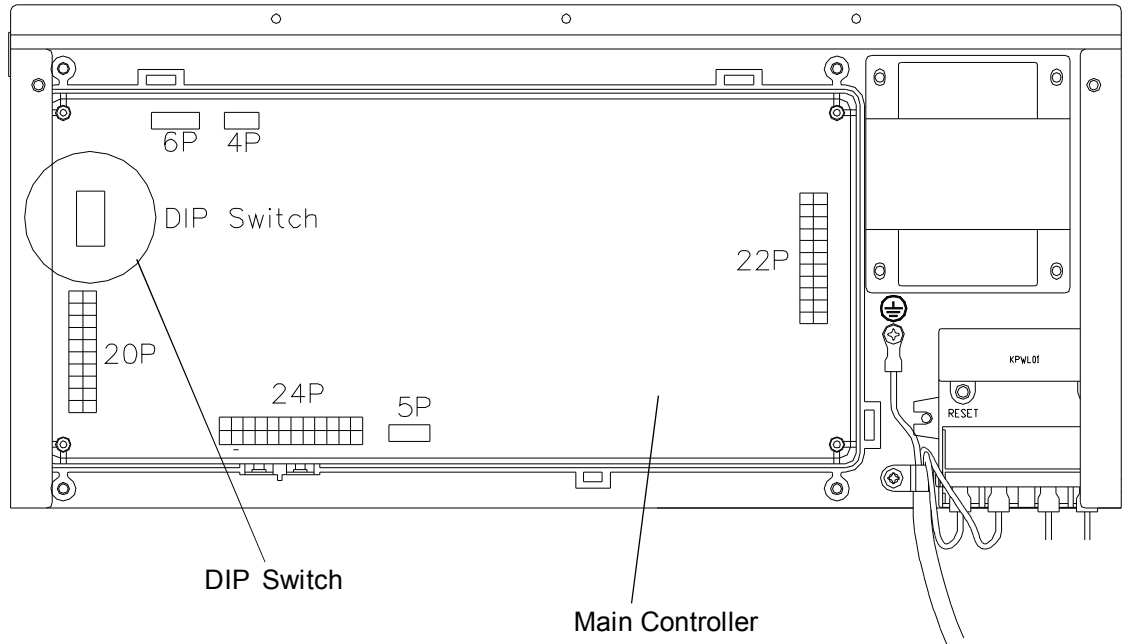

Default Setting Layout

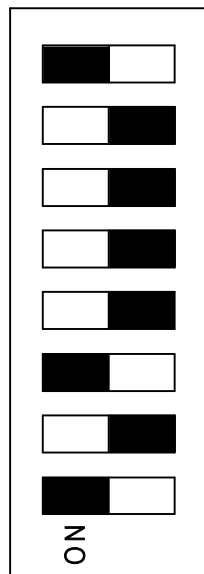

switch 8 : NG / LPG

switch 7 : maximum gas input selection 1

switch 6 : 20 PV / 26 PV or 28 PV / 32 PV

switch 5 : OFF

switch 4 : MCU function

switch 3 : Temperature selection 1

switch 2 : Temperature selection 2

switch 1 : Temperature selection 3

Wiring and Connection Diagram

WIRING DIAGRAM
157010131

MODEL : 501(11,12,21,22)1(20,26,28,32)1

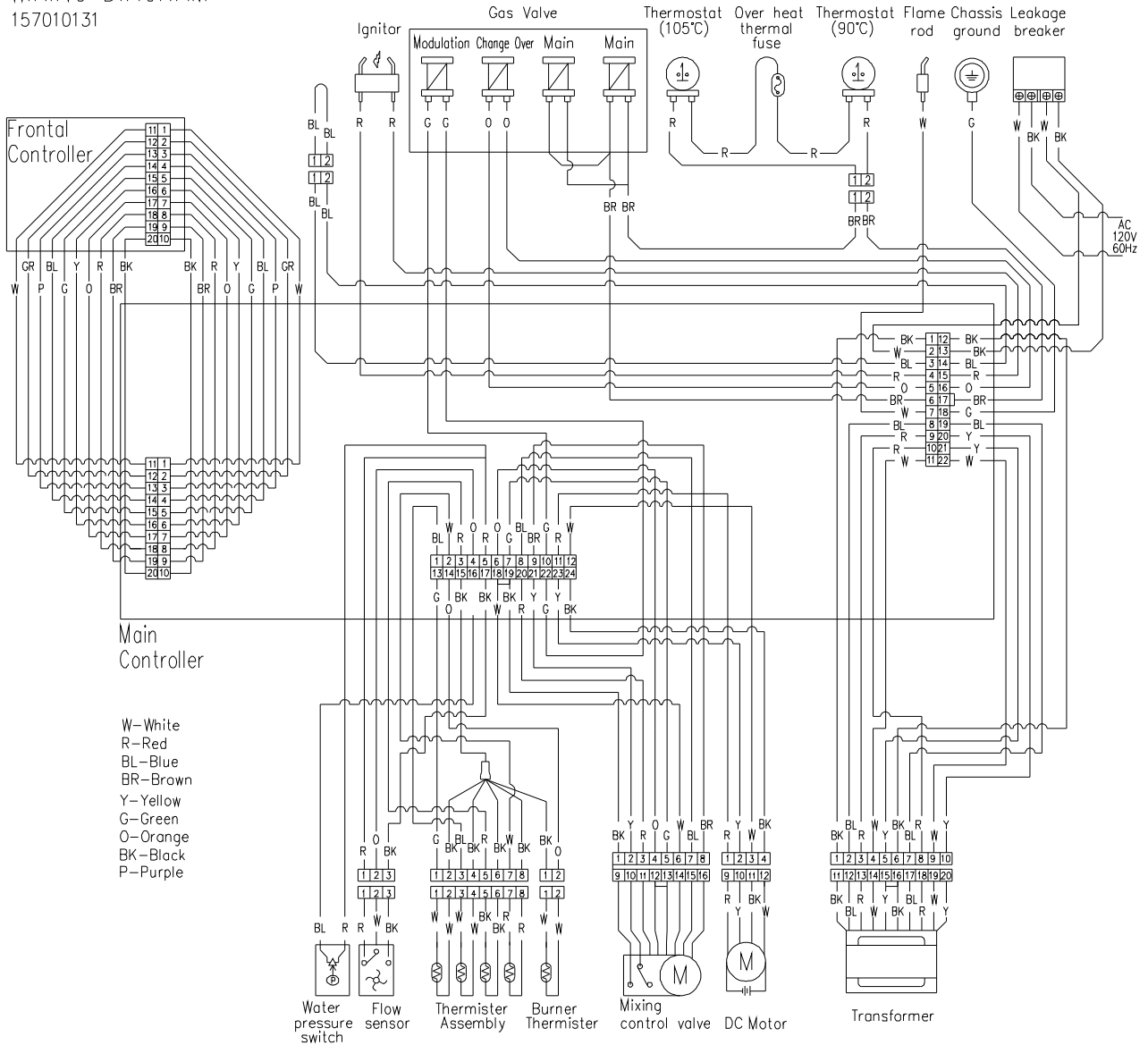

Liquid Propane Gas(LPG) Conversion

Remove Casing From Water Heater

1. Loosen 4 screws securing the Exhaust Collar and remove Exhaust Collar from Water heater. Loosen 2 screws securing Top Panel and push towards the rear of the unit and remove the Top Panel. Loosen 2 screws securing the Front Panel on the bottom front, and push downwards to remove the Front Panel.

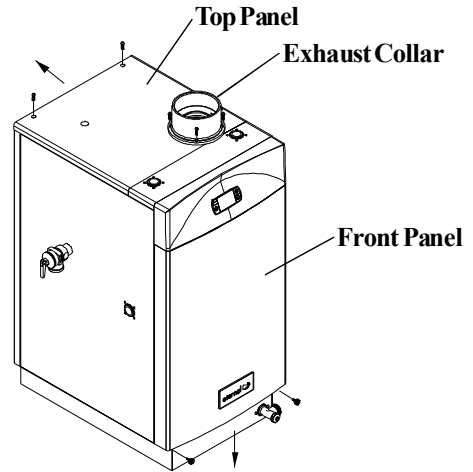

2. Loosen 2 screws securing the Control Panel Assembly to the frame, and remove the Assembly from Water Heater.

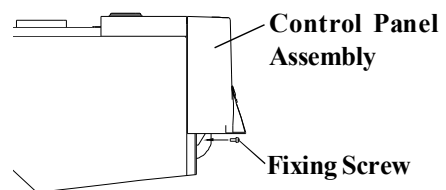

Install LP Kit Assembly

3. Loosen the nut of the existing gas pipe connected to the Nozzle Holder, and loosed the NG orifice. Remove the NG orifice from the Nozzle Holder and remove the gas pipe by loosening the 2 screws securing the gas pipe to the gas valve's Connector Bracket.

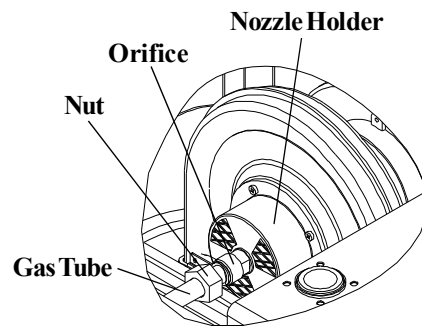

WARNING

Gas Tube can be bent if the nut and orifice are wrenched too hard. Make sure a 15MM wrench is used to hold the orifice while using a wrench to loosen the nut.

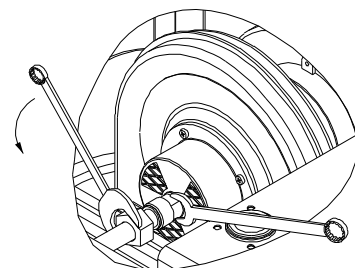

4. Loosen the 4 screws securing the Nozzle Holder to the blower and remove the Nozzle holder. Remove the Air Mesh.

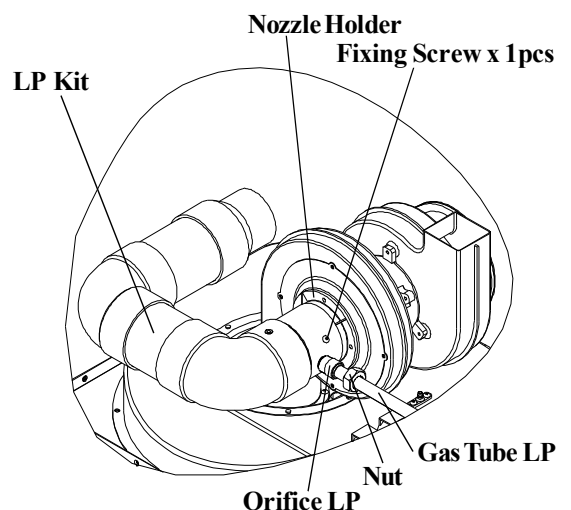
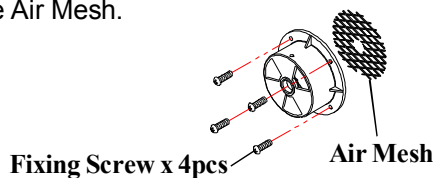

5. Reinstall the Nozzle Holder and secure with the same 4 screws previously loosened. Install the LP Kit Assembly over the Nozzle Holder and secure with the included screw. Connect Gas Tube LP to the LP Kit Assembly and tighten the nut to ensure good connection between Gas Tube LP and LP orifice on the LP Kit Assembly.

Liquid Propane Gas(LPG) Conversion

Replace NG Valve Adaptor With LPG Adaptor

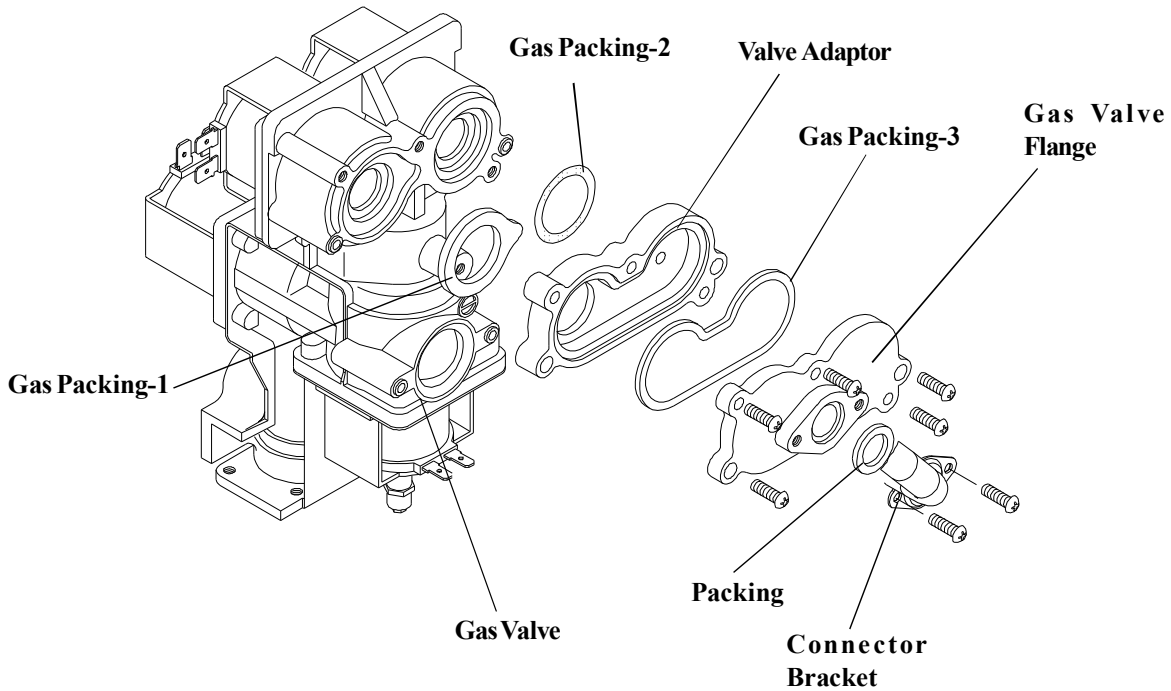

- 6 . Loosen and remove 5 screws securing the Gas Valve Flange. Remove the Gas Valve Flange, Packing and Valve Adaptor(NG). Replace Valve Adaptor(NG) with Valve Adaptor(LP). Reverse the steps above by reassembling the packing, Gas Flange and Connector Bracket. Make sure all screws and secure and tightened.
- 7 . Change Dip Switch No.8 position from left to right.

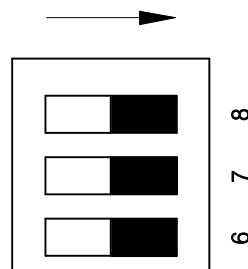

Reassemble Water Heater Casing

- 8 . Attach Top Panel and back on frame of the water heater and tighten the 2 screws. Attach Exhaust Top on Top Panel and tighten the 4 screws. Attach Control Panel Assembly to frame and tighten the 2 screws on the bottom of the panel. Remove The NG Label. Stick LPG label on the Panel.

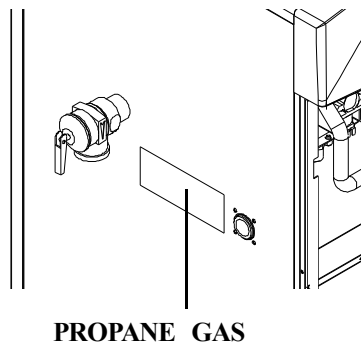

Recirculation System with an Eternal Water Heater

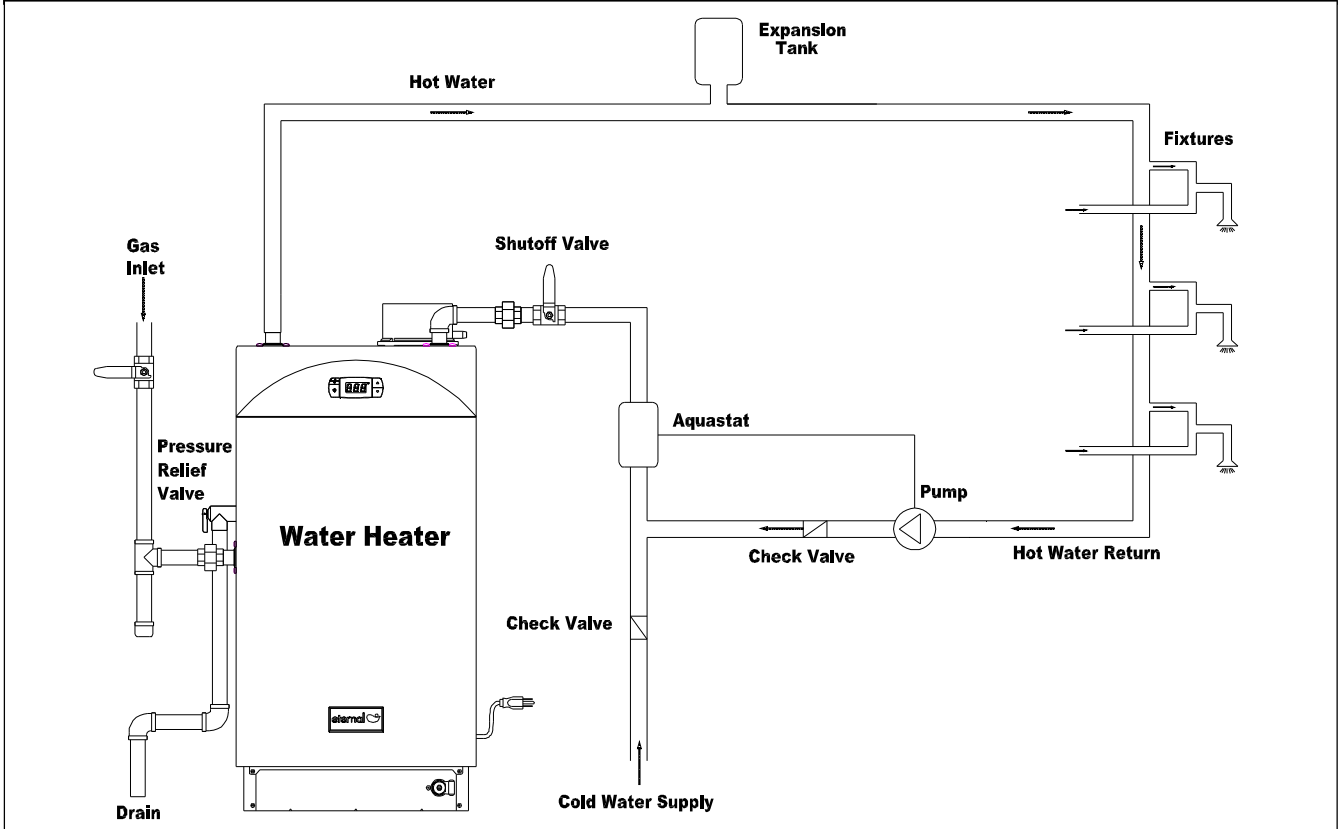

Single Eternal with Storage Back-up

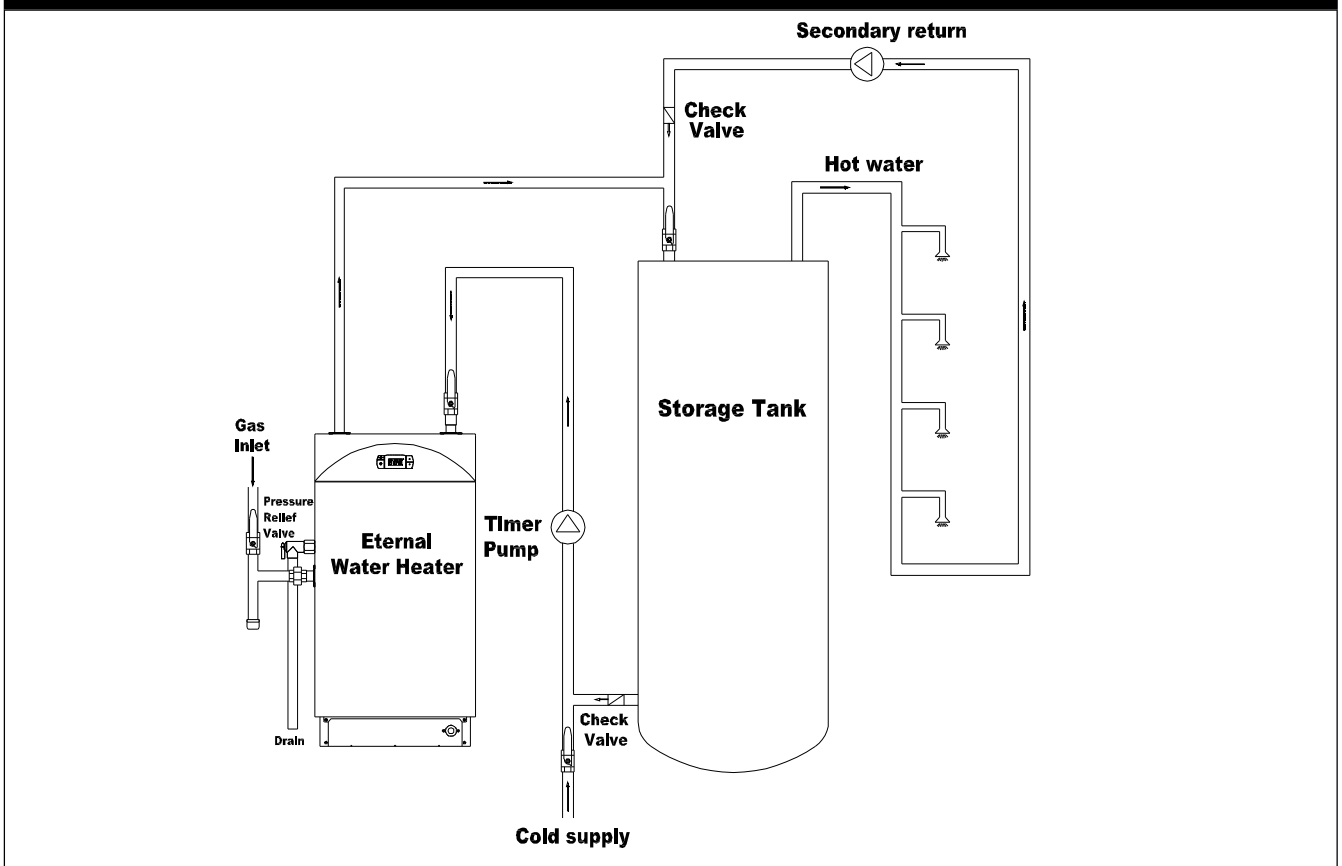

These diagrams are for reference as basic guides. Each installation should be engineered properly and compliant to Local and State Codes.

Recirculation with 2 Units manifold

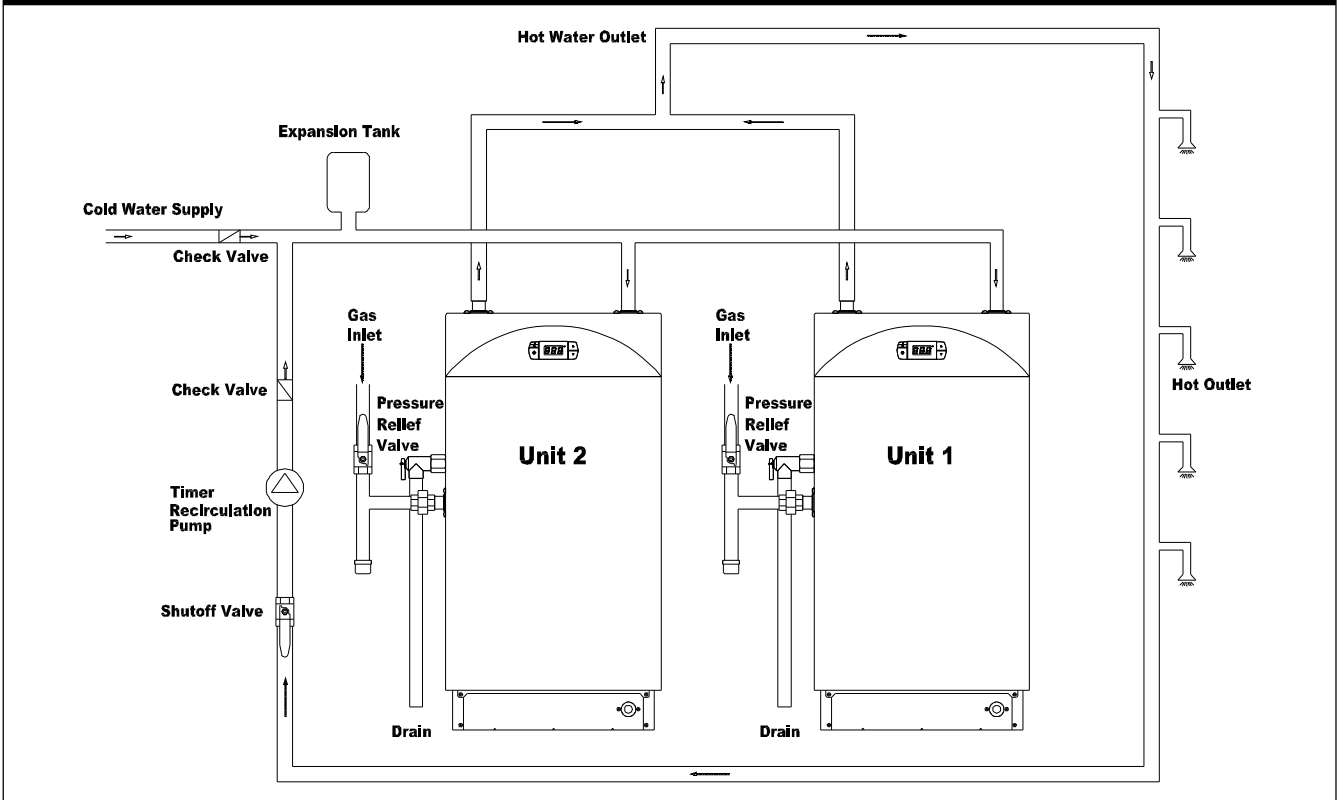

Single Eternal with pre-heater, i.e. Solar

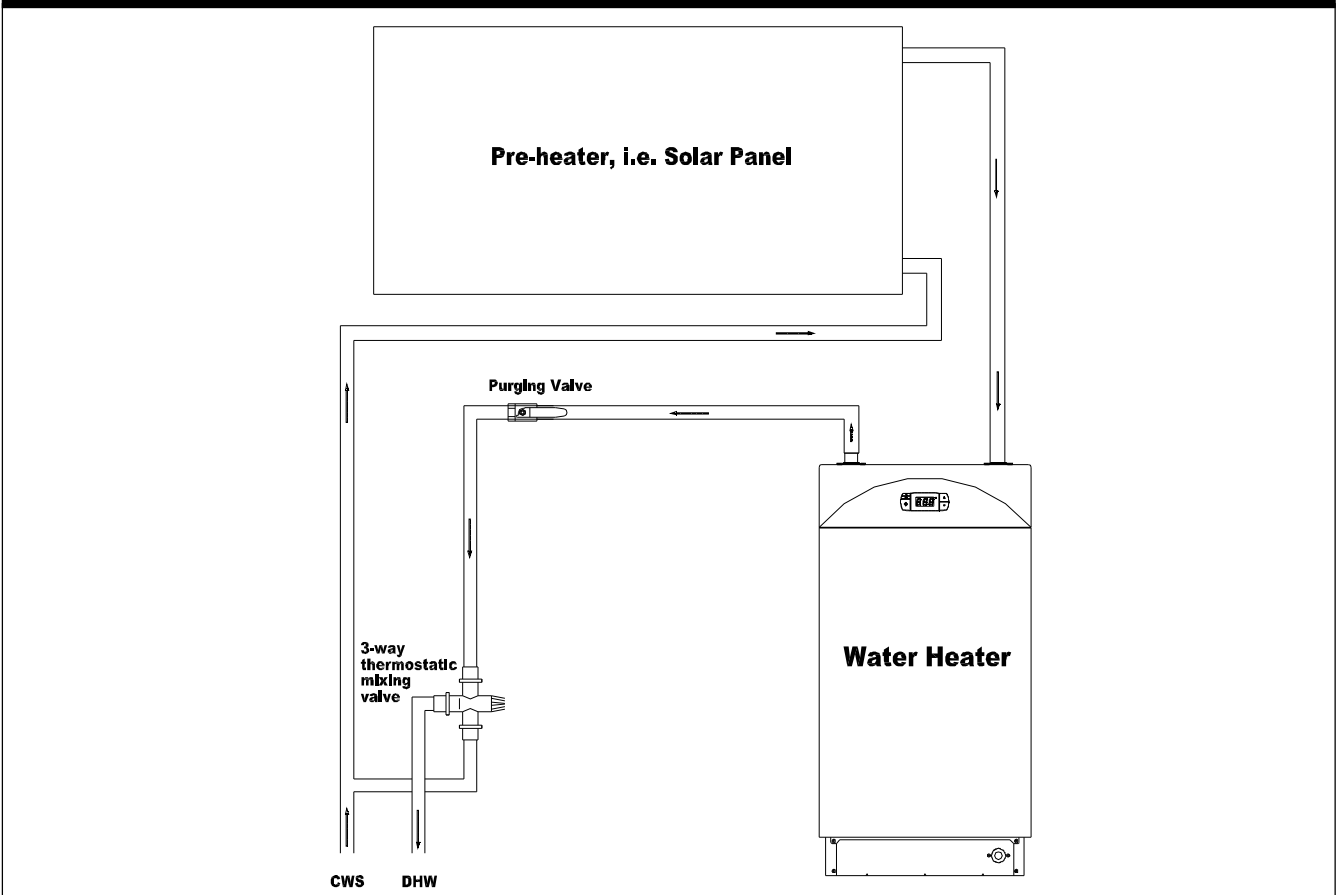

These diagrams are for reference as basic guides. Each installation should be engineered properly and compliant to Local and State Codes.

Grand Hall Limited Warranty

Grand Hall will warrant to the ORIGINAL PURCHASER of this gas water heater that it will be free of defects in material and workmanship for set period below from the date of purchase when installed and operated in a single-family residence in accordance with the instructions in the manual and all local/state/federal codes.

Heat Exchanger Tank - 20 Years No Leak Warranty
All Parts - 3 Years Limited Warranty
Reasonable Labor -1 year

Grand Hall will require reasonable proof of your date of purchase. Therefore, you should send in the owner registration card or register online at www.eternalwaterheater.com. Save your receipt in case it is required as proof of purchase.

This Limited warranty is limited to repair or replacement of parts, at Grand Hall's option that proved to be defective under normal residential use utilizing potable water.

Grand Hall may require the return of defective parts for examination before issuing replacement parts or repairs. If you are required to return defective parts, transportation charges must be prepaid.

No returns will be accepted without prior authorization from Grand Hall.

Upon examination and to Grand Hall's satisfaction, if the original part is proven defective Grand Hall may approve your claim and elect to replace such parts without charge. You are responsible for shipping charges of such replacement parts.

This Warranty does not cover any failures or operating difficulties due to accident, abuse, misuse, alteration, misapplication, vandalism, improper installation, maintenance or service, as set out in this Operator's Manual.

Deterioration or damage due to severe weather conditions such as hail, hurricane, earthquakes, tsunami, tornadoes, Acts of God or terrorism, discoloration due to exposure to chemicals either directly or in the atmosphere, is not covered by this Limited Warranty.

If service from authorized personnel is necessary to perform any work, you will be responsible for all labor charges outside of labor warranty period.

All replacement parts will carry out the remainder of warranty on the original parts.

To Obtain Warranty
Call 1-866-946-1096
8am - 4:30pm CST

Warranty Restrictions

- This warranty applies only when the water heater is used in the United States and Canada.
- This warranty gives you specific legal rights, and you may also have other rights which vary from state to state.
- This warranty does not cover damage resulting from use with non-potable water or water with high hardness level exceeding 450ppm. Water softener is recommended for areas with hardness over 200ppm.
- The heat exchanger warranty becomes limited 10 years No-Leak warranty when the water heater is installed for commercial applications or non-domestic potable hot water heating application.

Manufacturer:
Grand Hall Enterprise Co., Ltd.
9th Fl., No.298, Rueiguang Rd., Neihu,
Taipei, Taiwan (114)