



MX-200 Technical Specifications

MX 200

Includes: heater, secondary air regulator, oil by-pass regulator, pump assembly, primary waste oil strainer, check valve, barometric damper, oil supply strainer and thermostat.

FEATURES:

- UL Listed
- 200,000 BTU
- Fine grain galvanized (rust-resistant) cabinet
- MX Series High-Performance Burner
- Internal fan to reduce excess noise
- Adjustable, locking louvers
- Top, back, right or left exhaust options

Heat Range (btuh)*	to 200,000
Fuel Input (gph)	1.44
Heating Area (sq. ft.)**	to 7,000
Power Supply (AC)	120V. 60HZ
Cabinet Dimensions (H x W x L)	24" x 40.5" x 46.75"
Hanging Weight (lbs.)	413
Axial fan (cfm)	2,600
Chimney Pipe***	6" Class "A"
Compressed Air****	2 CFM - 15 PSI
Combustion Chamber	12 GA CRS
Chimney Location	Top / Left Side
Warranty (Parts/Chamber)	1 year / 10 year

* BTUH value varies with fuel type

** The suggested heating area is based on buildings with minimal heat loss due to open doors, construction, materials, windows, insulation, etc...

*** Chimney package is optional **** Customer supplied

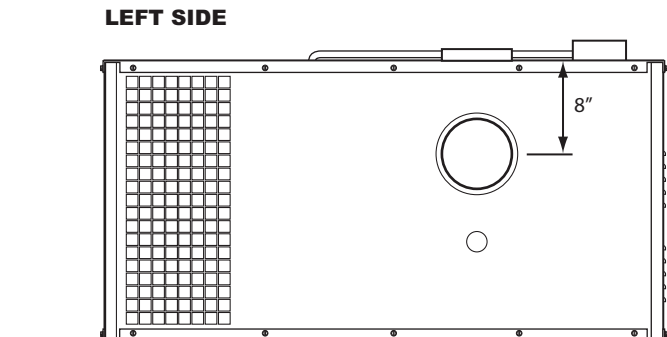
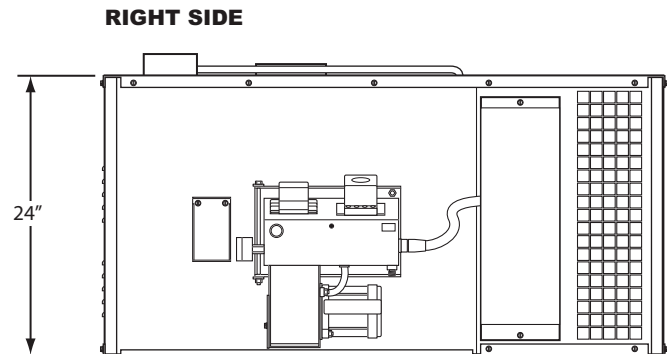
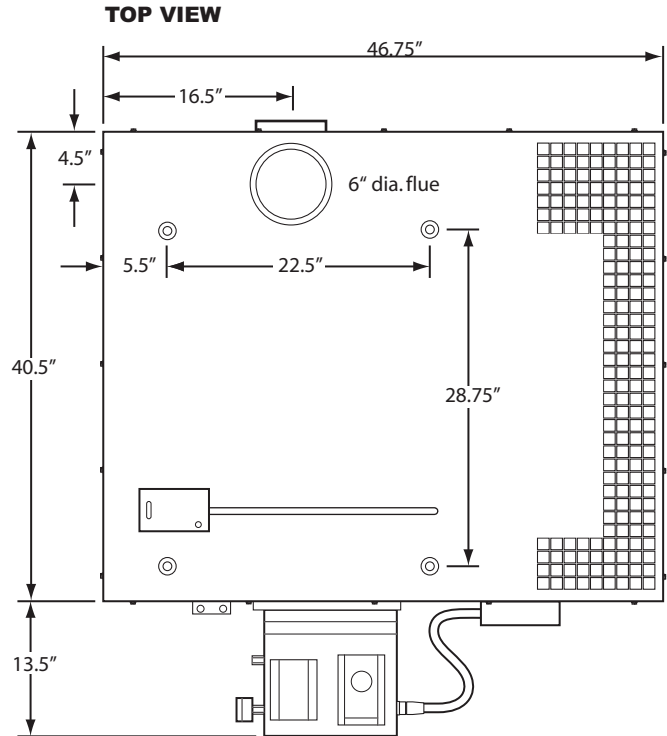

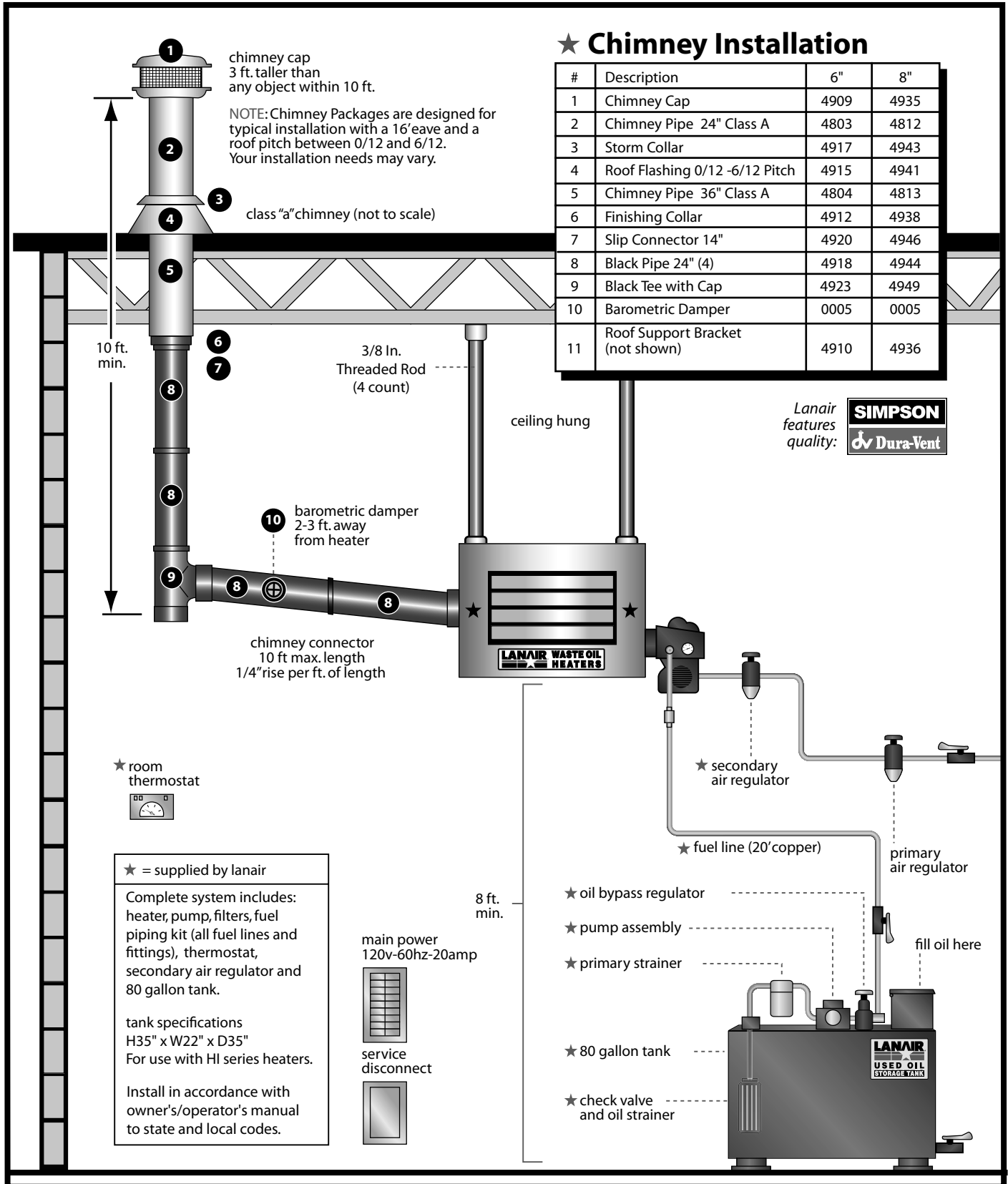

Specifications and designs subject to change without notice

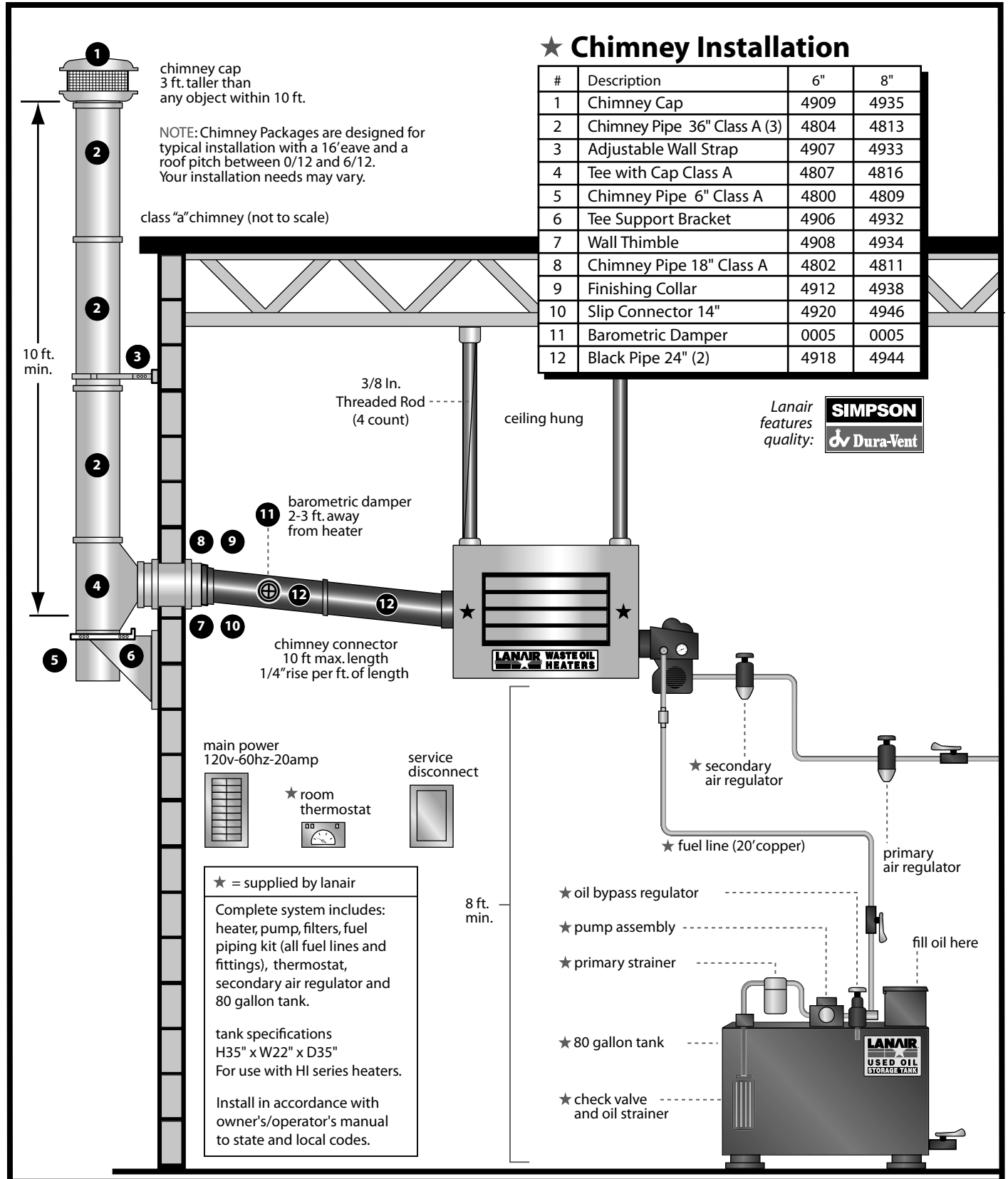

Specifications and designs subject to change without notice

Value Package C

Thru-Roof Installation



★ Chimney Installation

#	Description	6"	8"
1	Chimney Cap	4909	4935
2	Chimney Pipe 24" Class A	4803	4812
3	Storm Collar	4917	4943
4	Roof Flashing 0/12 -6/12 Pitch	4915	4941
5	Chimney Pipe 36" Class A	4804	4813
6	Finishing Collar	4912	4938
7	Slip Connector 14"	4920	4946
8	Black Pipe 24" (4)	4918	4944
9	Black Tee with Cap	4923	4949
10	Barometric Damper	0005	0005
11	Roof Support Bracket (not shown)	4910	4936

Lanair features quality:

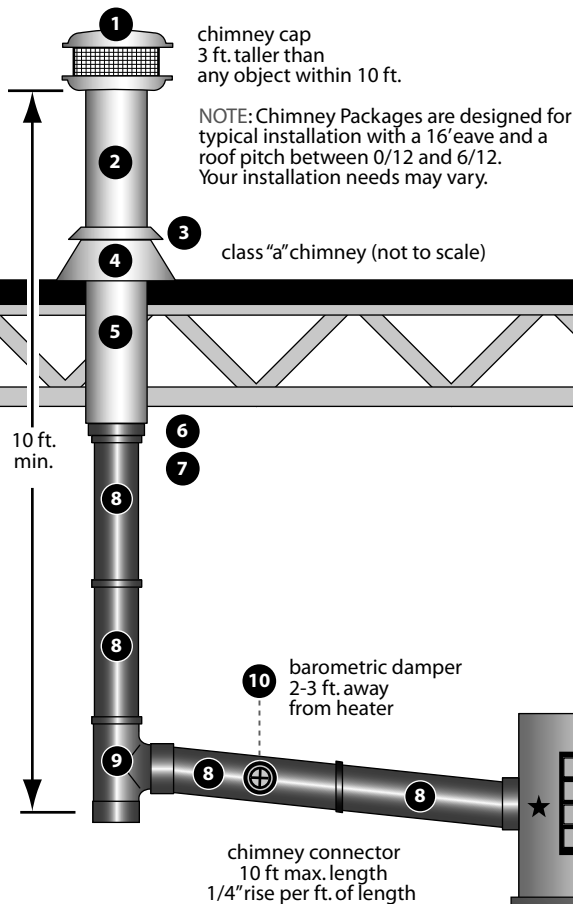

chimney connector
10 ft max. length
1/4" rise per ft. of length

10 barometric damper
2-3 ft. away
from heater

10 ft.
min.

main power
120v-60hz-20amp

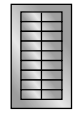

service
disconnect



★ room
thermostat



★ oil bypass
regulator

★ secondary
air regulator

8 ft.

★ = supplied by lanair

Complete system includes:
heater, pump, filters, fuel
piping kit (all fuel lines and
fittings), thermostat,
secondary air regulator and
215 gallon tank.

tank specifications
H35" x W36" x D46"
For use with HI series heaters.

Install in accordance with
owner's/operator's manual
to state and local codes.

Call us or visit our web site at: **1.800.753.1601** or **www.lanair.com**

Value Package D

Thru-Wall Installation



★ Chimney Installation

#	Description	6"	8"
1	Chimney Cap	4909	4935
2	Chimney Pipe 36" Class A (3)	4804	4813
3	Adjustable Wall Strap	4907	4933
4	Tee with Cap Class A	4807	4816
5	Chimney Pipe 6" Class A	4800	4809
6	Tee Support Bracket	4906	4932
7	Wall Thimble	4908	4934
8	Chimney Pipe 18" Class A	4802	4811
9	Finishing Collar	4912	4938
10	Slip Connector 14"	4920	4946
11	Barometric Damper	0005	0005
12	Black Pipe 24" (2)	4918	4944

Lanair features quality:

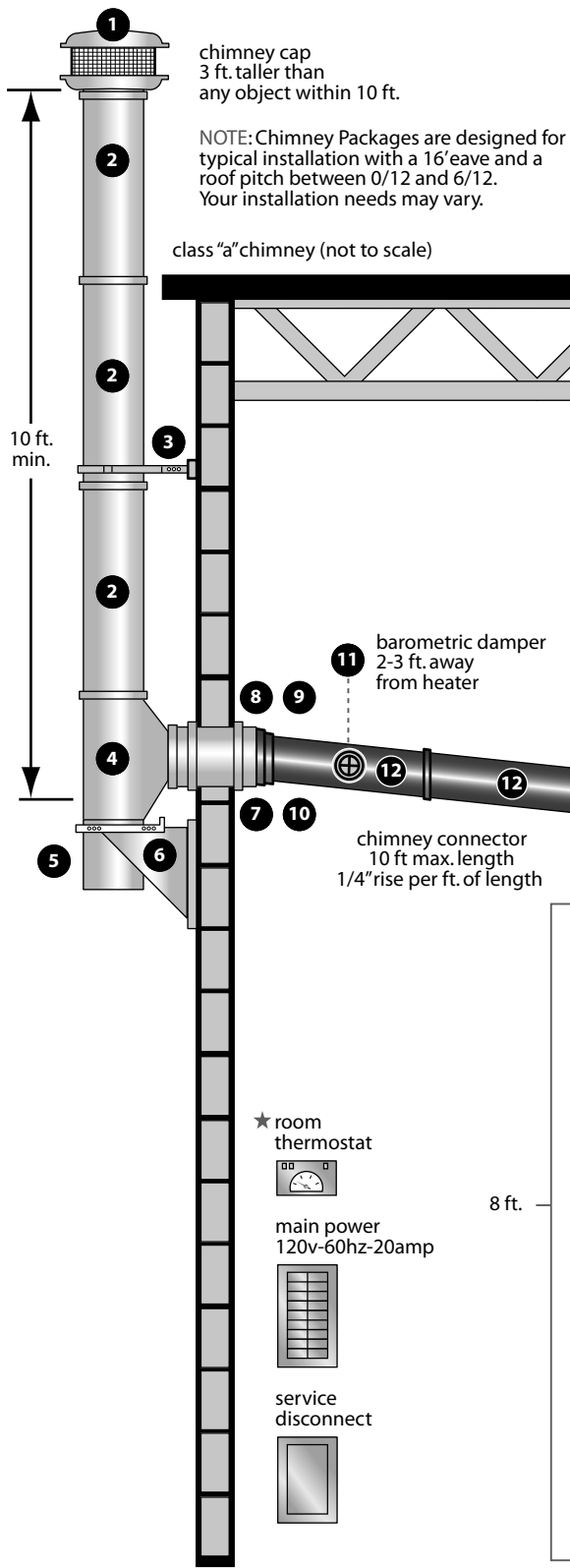

★ = supplied by lanair

Complete system includes:
heater, pump, filters, fuel piping kit (all fuel lines and fittings), thermostat, secondary air regulator and 215 gallon tank.

tank specifications
H35" x W36" x D46"
For use with HI series heaters.

Install in accordance with owner's/operator's manual to state and local codes.

Specifications and designs subject to change without notice

Call us or visit our web site at: **1.800.753.1601** or **www.lanair.com**